

Tahoe 2624

Barefoot Tofino Based Switch Appliance with Intel CPU & XEON® D Offload
24 Ports 100G/40G, 16 Ports 25/10G and Virtex UltraScale® FPGA Option.

Product Brief

Interface Masters

TECHNOLOGIES

Innovative Network Solutions

OVERVIEW

Interface Masters presents Tahoe 2624, a semi-modular 1U switch appliance based on **Barefoot Tofino**® high-speed switch fabric and managed by an Intel x86 control plane.

This semi-modular appliance supports two rear-facing I/O bays and can be upgraded with any combination of off-the-shelf **Intel XEON® D** based offload processing modules or the **Xilinx and Altera** performance leading FPGA modules. Additional rear-facing I/O modules can be developed based on your design requirements.

In standard configuration, Tahoe 2624 supports twenty-four (24) ports of 100/40G QSFP28 and sixteen (16) ports of 25/10G SFP28. Additional port configurations can be developed based on customer requirements.

Software configurations include white box with ONIE SDK (on Barefoot) and a complete hardware specific SDK tool set for custom development. Barefoot Deep Insight, Barefoot P4 Studio, development tools and software partner solutions available.

Interface Masters proudly designs and manufactures all our products in the USA.

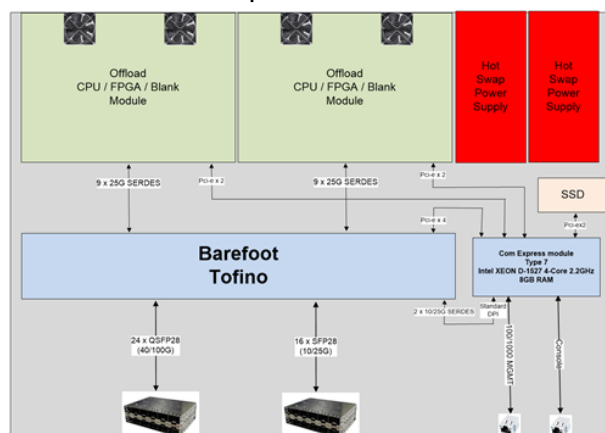

Block Diagram of Tahoe 2624



Tahoe 2624 (ISO View)

Product Features

Barefoot Tofino Switch Fabric

- 24 ports of 100/40G QSFP28
- 16 ports of 25G SFP28

Intel Control Plane

- Powerful x86 control plane

Two Best-In-Class Processing Modules

- Intel XEON® D Off-Load Processing I/O
- Xilinx and Altera FPGA I/O module
- Any combination, validated on a single system

Dual Redundant Hot-Swappable Power Supplies

- High-efficiency power supplies (AC/DC or DC/DC)

Management Interfaces

- Dedicated RS-232 console port
- Dedicated 10/100/1000 management port

Security

- Standard Trusted Platform Module (TPM)
- Optional security (FIPS 104-2 Level 3, GPS, tamper proofing)

Other

- Standard IEEE-1588 PTP support

Software

- ONIE SDK (on Barefoot)
- SONiC tested
- Protocol Independent Switch Architecture (PISA) with P4 programmability
- SDK with complete hardware specific SDK tools for custom development
- Custom development and support

ENVIRONMENTAL	
Operating Temperature	0° to 40 °C (32° to 104°F)
Storage Temperature	-20° - 65°C (-4°F to 149°F)
Operating Humidity	5% to 85%, non-condensing
Airflow	100+lf/m

DIMENSIONS		
	Inches	Millimeter
Length	24.25	615.95
Height	1.75	44.45
Width	17.25	438.15

PRELIMINARY POWER CONSUMPTION	
Typical	Maximum
Application Dependent	282W

ORDERING INFORMATION	
Part Number	Description
Tahoe 2624	Advanced Barefoot Tofino switching appliance with 24 ports of 100/40G QSFP28 and 16 ports of 25/10G SFP28. Intel x86 powerful control plane. Supports two rear-facing I/O Bays.
IM13297	I/O module with Intel XEON D off-load processor, plus fans.
IM13298	I/O module with Xilinx Virtex UltraScale® Performance-Leading FPGA module, plus fans.
IM13299	I/O Module with integrated fans.

CUSTOMIZATION SERVICES

Hardware, Firmware, Linux O/S and application code development services available.



ABOUT INTERFACE MASTERS TECHNOLOGIES, INC.

Interface Masters Technologies is a leading provider of high-speed networking solutions focused on 1/10/25/100/200 Gigabit Ethernet networking solutions. For over 25 years, Interface Masters Technologies has been providing innovative networking solutions with customization services to OEMs, large enterprises and sophisticated end users. Interface Masters Technologies provides Ethernet switches, appliances, server adapter cards with high port density, networking offload and bypass functionality. Company headquarters are located in San Jose, CA with satellite offices in Hong Kong and Europe.

Barefoot Tofino® is a trademark of Barefoot Networks.

XEON® D and Altera® are trademarks of Intel Corporation.

Virtex UltraScale® is a trademark of Xilinx Corporation.