

Cisco Network Convergence System NCS 5500 Modular Platform Architecture



Last Updated: Dec 2016

Authors – SP Routing Infrastructure Marketing

Table of Contents

NCS 5500 FAMILY INTRODUCTION	3
NCS 5508 PLATFORM ARCHITECTURE	3
HARDWARE COMPONENTS OVERVIEW	5
Route Processor Module	5
System Controller Module	6
Power Supplies	8
Modular Fan Trays	9
Fabric Modules	10
NCS 5500 Platform Line Cards	11
CONCLUSION	16

NCS 5500 Family Introduction

The Network Convergence System 5500 Series offers industry-leading density of routed 1/10/40/100G ports for high-scale WAN aggregation. The NCS 5500 Series is designed to efficiently scale across Data Centers, Large Enterprise, Web, Service Provider WAN and Aggregation Networks.

The Cisco NCS 5500 is a family of routing platforms including fixed and modular chassis. The platform offers high port density, high performance forwarding, low jitter and the lowest power consumption per Gigabits/sec at a very cost-effective price point.

The NCS 5500 leverages the industry-leading IOS XR Operating System with a full suite of standard layer-2 and layer-3 protocols, plus new features and functions such as:

- Application Hosting
- Programmability
- Enhanced Automation
- Machine to Machine interface (M2M)
- Telemetry
- Flexible Package Delivery

This white paper focuses on the hardware architecture, characteristics and packet forwarding of NCS 5500 modular platform.

NCS 5508 Platform Architecture

The NCS 5508 is an 8-Slot 13 RU modular chassis routing platform that supports industry-leading performance with up to 288 100G non-blocking ports. It occupies one-third of a rack with very low power consumption of approximately 0.24 W/Gbps. The NCS 5508 platform is highly reliable and resilient; its architecture is based on redundant route processors, system controllers, fabric modules, fan trays and power supplies.

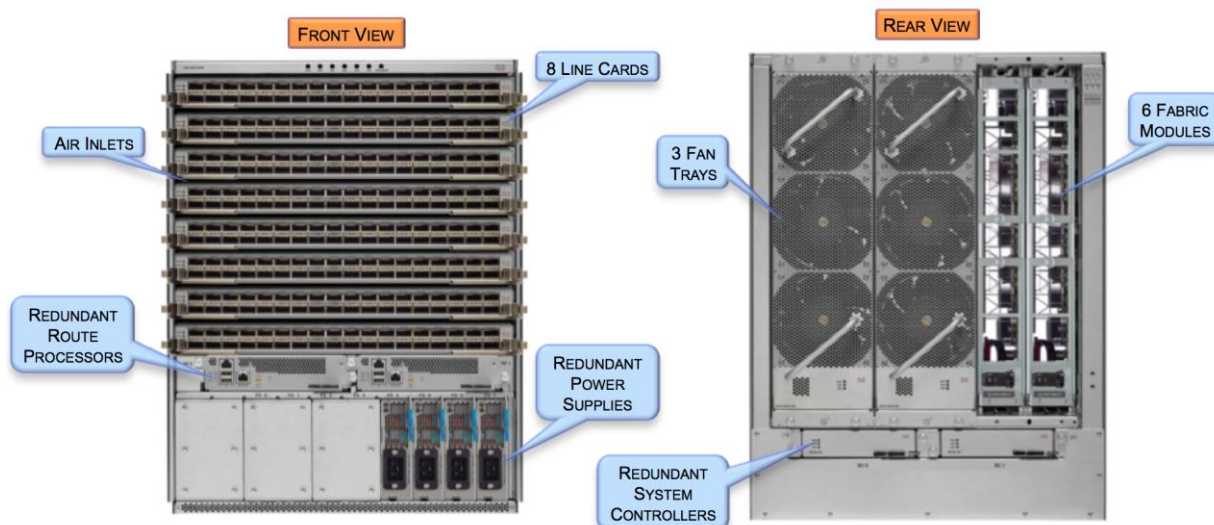

Figure 1- NCS 5508 Chassis Front View and Rear View

NCS 5508 Platform	Specifications
Chassis Height	13 RU – 1/3 rd of Rack
Chassis Dimensions	22.70 x 17.50 x 31.76 inches 57.78 x 44.50 x 80.67 cm
Number of Line Card Slots	8 Slots per Chassis
Route Processors	2 (1+1 Redundant RPs)
System Controllers	2 (1+1 Redundant SCs)
Fabric Modules	6 Fabric Cards (5+1 Redundant)
Fan Trays	3 Redundant Fan Trays
Power Supplies	8 x 3-kW AC or DC PSUs - (supports N+1, N+N Redundancy)
Air Flow	Front-to-Back Airflow
Max Port Density 40/100G	40G: 36 Ports x 8 Line Cards = 288 100G: 36 Ports x 8 Line Cards = 288
Max Forwarding Throughput / System	28.8Tbps

Table 1- NCS 5508 Router Characteristics

In most traditional modular platform designs, a backplane or mid-plane provides connectivity between the line cards and fabric modules. The NCS 5508 router platform is based on Cisco’s innovative “orthogonal” chassis design that eliminates the need for a mid-plane in a modular chassis.

With a precise alignment mechanism, NCS 5508 router line cards and fabric modules directly attach to each other with connecting pins. Line cards and fabric modules have the orthogonal orientations in the chassis so that each fabric module is connected to all line cards and vice versa.

Eliminating the need for a mid-plane provides advantages such as compact chassis design, efficient airflow and optimized cooling.

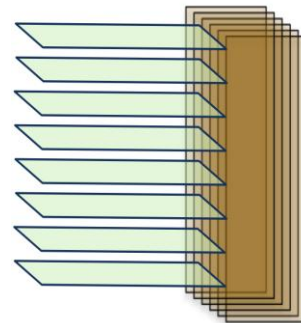

Figure 2- Orthogonal Direct Design

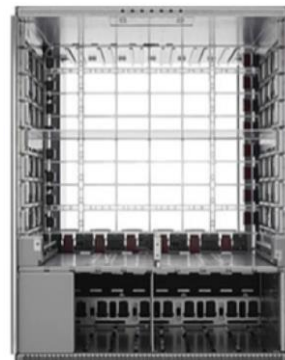

Figure 3- Mid-plane free Chassis

Hardware Components Overview

Route Processor Module

The route processor in NCS 5508 platform provides control plane functions while all the data plane functionality is moved to the line card and fabric modules. The NCS 5508 platform supports redundant half-width route processors that are responsible for control plane functions. The route processor is based on an Intel 6-Core CPU operating at 2.2GHz with 24GB of RAM. There is a built-in 256GB of Flash storage SSD which is part of the file system to provide additional on-board space for persistent storage.

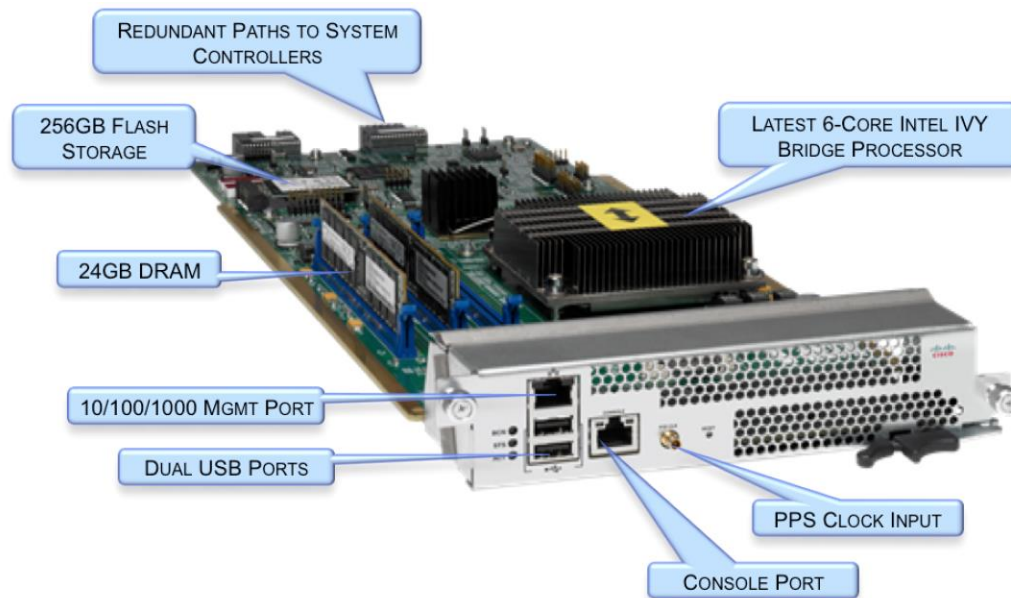

Figure 4- NCS 5508 Route Processor

The NCS 5508 can host two route processor modules, though only one route processor is active at a time. The other route processor operates in standby mode, ready to assume control if the primary fails, providing stateful switchover.

The route processor's high-speed multi-core CPU and large memory base builds the foundation for a highly available platform and provides very fast convergence in case of failure. The route processor runs Cisco's 64-bit IOS XR Operating System. The 64-bit IOS XR enables better processing performance and faster access to system memory. It also provides the ability to create containers to run third-party applications. These advantages plus the new feature enhancements such as telemetry, programmability and flexible packaging in IOS XR, builds a solid foundation for NCS 5500 platforms.

Out-of-band management is available via a 10/100/1000Mbps Management Ethernet interface and a serial RS-232 console port. There are two USB2.0 interfaces that can be used for disaster recovery and also to transfer system images and logs.

The communications between the route processor and the fabric modules or line cards utilize either Ethernet Out-of-Band Channel (EOBC) or Ethernet Protocol Channel (EPC). Both channels have a central hub on the system controllers providing redundant paths.

Route Processor	Specifications
Processor	Intel 6-Core processor @ 2.2 GHz
System Memory	24GB DRAM
Flash Storage	256GB Flash SSD Storage
Out of Band Management	10/100/1000Mbps Management Ethernet Port
Console Port	1 x RS-232 Serial port
USB Interface	2 x USB 2.0 slots

Table 2- NCS 5508 Route Processor Specifications

System Controller Module

The system controller of NCS 5508 platform offloads the chassis control and management functions from the route processor module. The system controller is based on a dual-core ARM CPU operating at 1.3GHz. It provides intra-chassis communication between the hardware components as well as a central point of control for the fans, power supplies and other hardware elements in the NCS 5508 chassis.



Figure 5- NCS 5508 System Controller

For the intra-chassis communication there are two main logically isolated control and management communication paths; Ethernet Out-of-Band Channel (EOBC) and Ethernet Protocol Channel (EPC).

Ethernet Out-of-Band Channel (EOBC)

EOBC is a 1/2.5Gbps¹ switch for inter-process communication or device management in NCS 5508. All system management communication across modules takes place through the EOBC channel. The EOBC channel is provided via a switch chipset on the system controllers that inter-connects all modules together, including route processors, fabric modules and line cards.

Ethernet Protocol Channel (EPC)

EPC is a 1/2.5Gbps switch for intra-node data plane protocol packets communication in the NCS 5508. Unlike the EOBC channel, the EPC switch only connects fabric modules to route processors. It is responsible for sending control plane packets to the route processor or to the line card CPU. If protocol packets need to be sent to the route processor, line cards utilize the internal data path to transfer packets to fabric modules. The fabric modules then redirect the packet via the EPC channel to the route processors.

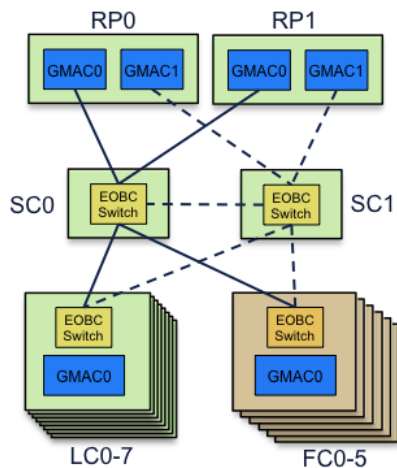

Figure 6- NCS 5508 EOBC Network

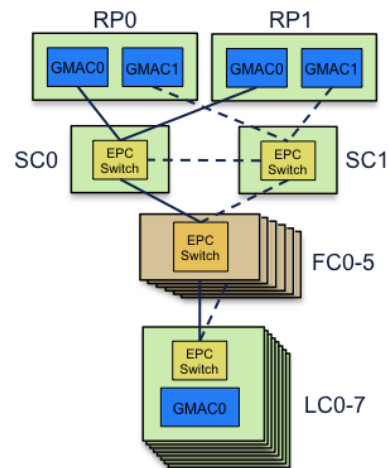

Figure 7- NCS 5508 EPC Network

The system controller also communicates with and manages power supply units and fan controllers via the redundant system management bus (SMB).

The NCS 5508 platform supports redundant system controllers. Only one system controller will be active at a time in a chassis, the second system controller will assume the secondary or standby role to provide redundancy.

¹ 1Gbps or 2.5Gbps is dependent on the type of line card.

Power Supplies

The NCS 5508 power supply modules deliver fault tolerance, high efficiency, load sharing, and hot-swappable features to the platform. Each NCS 5508 chassis can accommodate up to 8 AC or DC power supplies though only 5 power supplies (all must be one type or the other) are required to provide N+1 redundancy for a fully loaded chassis. The power supplies provide internal component-level monitoring, temperature sensors, and intelligent remote-management capabilities.

The DC power supply provides 3-kW output power from input power sources. It can accept a single or dual DC input sources; it will deliver 1.5-kW when only 1 input is active and 3-kW when 2 inputs are active.

The AC power supply utilizes a single input to provide 3-kW output power. The power supplies are platinum-rated and offer 91% plus efficiency, so less power is dissipated as heat and more power is available for the system to use than with typical power supplies.



Figure 8- NCS 5508 AC Power Supply



Figure 9- NCS 5508 DC Power Supply

Power Supply Units (PSU)	Specifications
Input Power AC Power Supply	3000W at 210 – 264V AC
Output Power AC Power Supply	3000 Watts
Input Power DC Power Supply	-40 to -75V DC -48 to -60V DC
Output Power DC Power Supply	3000 Watts
Efficiency	Platinum Rated Power Supply with 91% plus efficiency
Min / Max PSU per Chassis	1 PSU min – 8 PSU max
Redundancy	5 PSU provide N+1 redundancy for a fully loaded chassis

Table 3- NCS 5508 AC and DC Power Supply Specifications

Modular Fan Trays

The NCS 5508 platform can host three redundant hot-swappable fan trays with 3 dual fans per tray. The fan trays support front-to-back air flow and adjust speed accordingly to compensate for changing ambient temperature and fan failures.

The fan trays are installed behind the fabric modules in the back of the chassis and have to be removed in order to service the fabric modules. As soon as the fan tray is removed the remaining fans increase the speed to 100% to prevent the overheating.

Inlet Temperature	Air Volume (cubic feet / min)	Acoustic Level	Fan Speed
<31 C	63 cfm	75 dB	3300 rpm
32 – 44 C	93 cfm	87 dB	5500 rpm
>45 C	109 cfm	92 dB	6500 rpm

Table 4- NCS 5508 Fan Tray Specifications

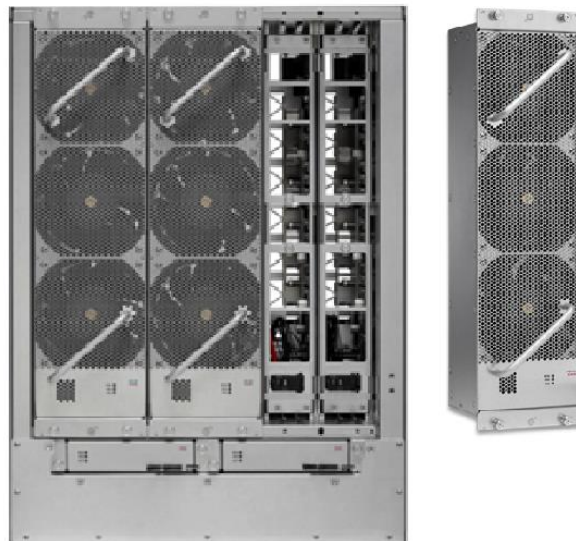

Figure 10- NCS 5508 Fan Tray installation

Fabric Modules

The Cisco NCS 5508 chassis has a CLOS fabric design that interconnects the line cards with rear-mounted fabric modules. The fabric modules provide the central switching elements for fully distributed forwarding on the line cards.

NCS 5508 platform supports up to six fabric modules, all are directly connected to all line cards. The addition of each fabric module increases the bandwidth to all module slots up to the system limit of six modules.

All active fabric modules work together delivering up to 5.4Tbps of fabric capacity per line card. The architecture supports lossless fabric failover, with the remaining fabric modules load balancing the bandwidth to all the line card slots, helping ensure graceful degradation.



Figure 11- NCS 5508 Fabric Module

Fabric Modules	Specification for NCS 5508
Fabric Modules	6 Fabric Modules / chassis
Fabric Module Redundancy	N+1 Redundancy – Graceful Bandwidth reduction if 2+ are down
Forwarding ASICs	2 Fabric ASICs / Fabric Card

Table 5- NCS 5508 Fabric Module Specifications

Inside each of the Fabric Module of NCS 5508 platform there are two Fabric ASICs called Switch Fabric Element (SFE). The line cards and fabric modules perform cell-based forwarding via Switch Fabric Elements. When a packet comes in a line card and has to get switched through the Fabric Module, the packet is segmented into smaller sized cells (64 to 256 bytes) sent evenly across Fabric Cards. This round-robin approach to distribute cells to all the available Fabric Cards provides the required data path bandwidth and packet forwarding capacity to achieve a true non-blocking architecture. It also permits the router to forward single flows with no bandwidth limitation.

NCS 5500 Platform Line Cards

The NCS 5508 chassis supports various types of line cards to provide 10G, 25G, 40G and 100G data speeds, each chassis can accept line cards of different types. All the first-generation line cards support Quad Small Form-factor Pluggable (QSFP) front panel ports, each port can be used for either 40G or 100G speeds; the 40G ports can be used as 4 x 10G ports in breakout mode so that each port can operate as four separate 10G ports providing greater speed flexibility. 40G, 4x10G and 100G ports can be mixed and matched in the same forwarding ASIC.

The line cards also have a built-in 8-Core ATOM CPU to offload some control plane tasks from route processor, improving the control plane performance:

- Programming the hardware table resources
- Collecting/sending line card counters and statistics
- Processing BFD and ICMP packets

Depending on the port types and density, the line cards use three, four or six forwarding ASICs. These FA use a 16MB on-chip memory for normal operation and a 4GB external buffer to handle up to 50ms of packet queuing in case of interface congestion.

Traffic destined for a different line card or different forwarding ASIC can be distributed across six fabric modules, while traffic targeted to a port located on the same FA will be switched/routed locally.

NCS 5500 36x 100G Line Card

The NCS 5500 36x 100G line card provides the highest density at line rate performance on each port. This line card uses six forwarding ASICs with on-chip packet buffers, on-chip routing tables and off-chip deep buffer.

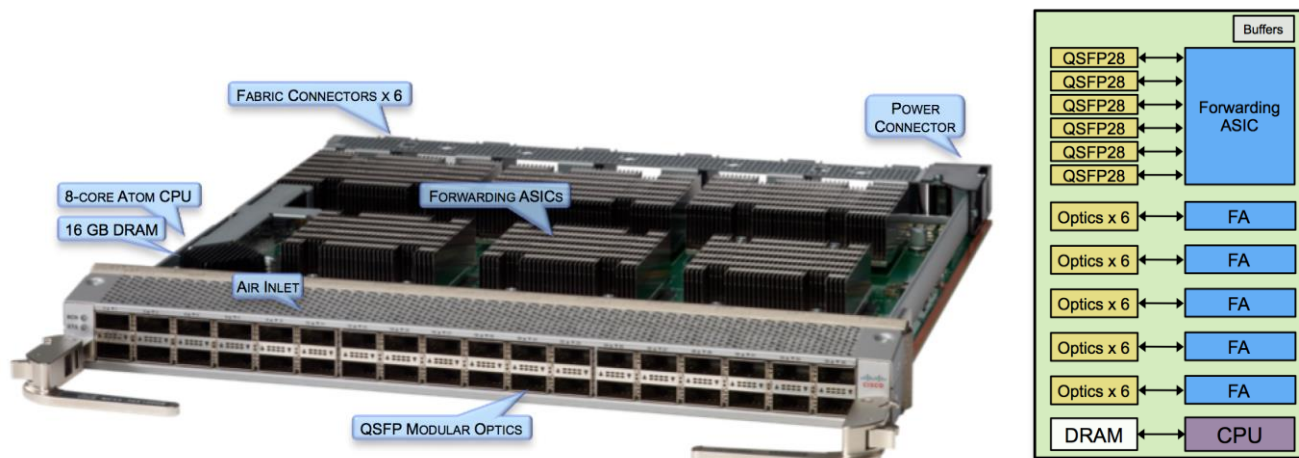

Figure 12- NCS 5500 36x 100G Line Card

This line card delivers up to 4,320 million packets per second (Mpps) and up to 3.6Tbps of data forwarding. NCS 5500 36x 100G line card contains six forwarding ASICs, each offering 600Gbps of bandwidth with 720Mpps of throughput. On-chip tables provide a minimum of 256K IPv4 or 64K IPv6 routes (350K IPv4 or 160K IPv6 with internet prefixes distribution) and 750k for IPv4 /32 and /24 routes shared with MPLS and MAC addresses.

The forwarding ASIC on the line card delivers 600Gbps of bandwidth in each direction.

NC55-36X100GE	Specifications
Ports	36x 40/100G QSFP Ports 144x 10G SFP Ports via Breakout
Forwarding ASICs	6 Forwarding ASICs x (600Gbps bandwidth each)
Resources	On-chip tables for a minimum of 256K IPv4 or 64K IPv6 routes (350K IPv4 or 160K IPv6 with Internet distribution) On-chip tables for 750K IPv4 routes, MAC and MPLS labels
Buffers	16MB On-chip Buffers 4GB Off-chip Buffers
Packet Forwarding Rate	Up to 4,320 Mpps (6x 720 Mpps)
Forwarding Throughput	3.6Tbps
Latency	2 to 8 usec

Table 6- NCS 5500 36x 100G Line Card Specifications

NCS 5500 24x 100G Scale Line Card

The NCS 5500 24x 100G line card provides the highest routing scale of the portfolio along with line rate performance on each port. The extended scale is achieved for FIB, ACL and QoS by utilizing a 10MB external-TCAM. This external-TCAM is used in addition to the On-Chip table. The Off-chip/external-TCAM provides up to 2M entries that can be shared between IPv4, IPv6 routes, ACL and QoS. The on-chip table provides 750k entries for IPv4 routes, MPLS Labels and MAC addresses. Globally, the system supports up to 2.75M prefixes.

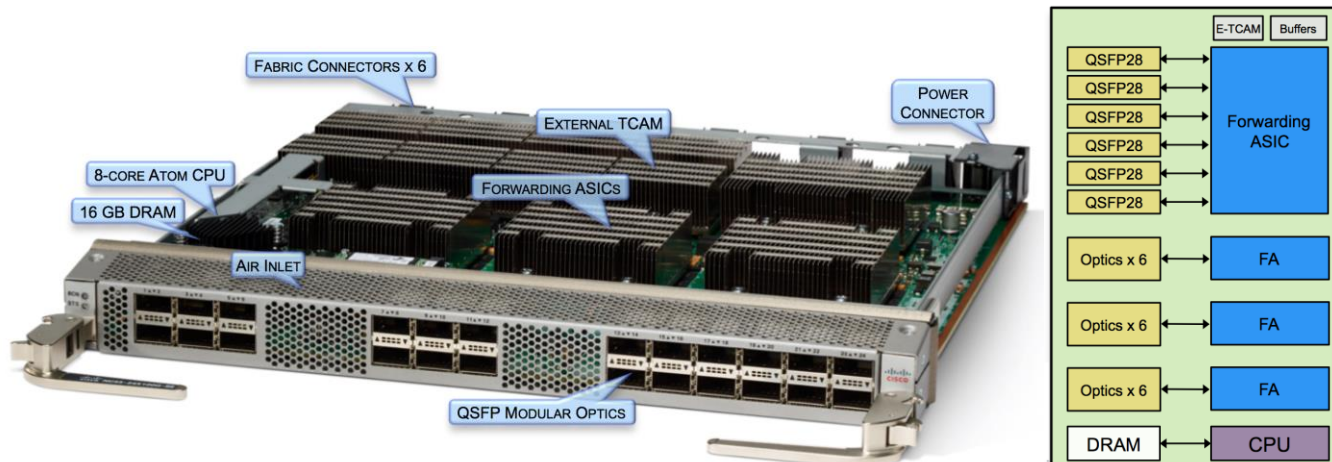

Figure 13- NCS 5500 24x 100G External-TCAM Line Card

This line card delivers up to 2,400 million packets per second (Mpps) of distributed forwarding and up to 2.4Tbps of data throughput. NCS 5500 24x 100G line card contains four forwarding ASICs, each offering 600Gbps of bandwidth with 600Mpps of throughput.

NC55-24X100-SE	Specifications
Ports	24 x 40/100G QSFP Ports 96 SFP 10G Ports via Breakout
Forwarding ASICs	4 Forwarding ASICs x (600Gbps bandwidth each)
Resources	FIB scale up to 2M IPv4 or 1M IPv6 routes (FIB scale up to 2.75M IPv4 routes if combined with on-chip tables) On-chip tables for 750K IPv4 routes, MAC and labels
Buffers per Forwarding ASIC	16MB On-chip Buffers 4GB Off-chip Buffers
Packet Forwarding Rate	Up to 2,400 Mpps (4x 600 Mpps)
Forwarding Throughput	2.4Tbps
Latency	2 to 8 usec

Table 7- NCS 5500 24x 100G external-TCAM Line Card Specifications

NCS 5500 18x 100G + 18x 40G Line Card

The NCS 5500 18x 100G + 18x 40G line card provides optimized cost and power. It offers 36x 40G QSFP ports, 18 of them can be upgraded to 100G using a license.

When deployed as a 36x 40G line card, it offers line rate forwarding performance as it utilizes only 1.4Tbps out of the available 2.16Tbps of bandwidth. This line card gets 16% oversubscribed when deployed as 18x 100G + 18x 40G line card.

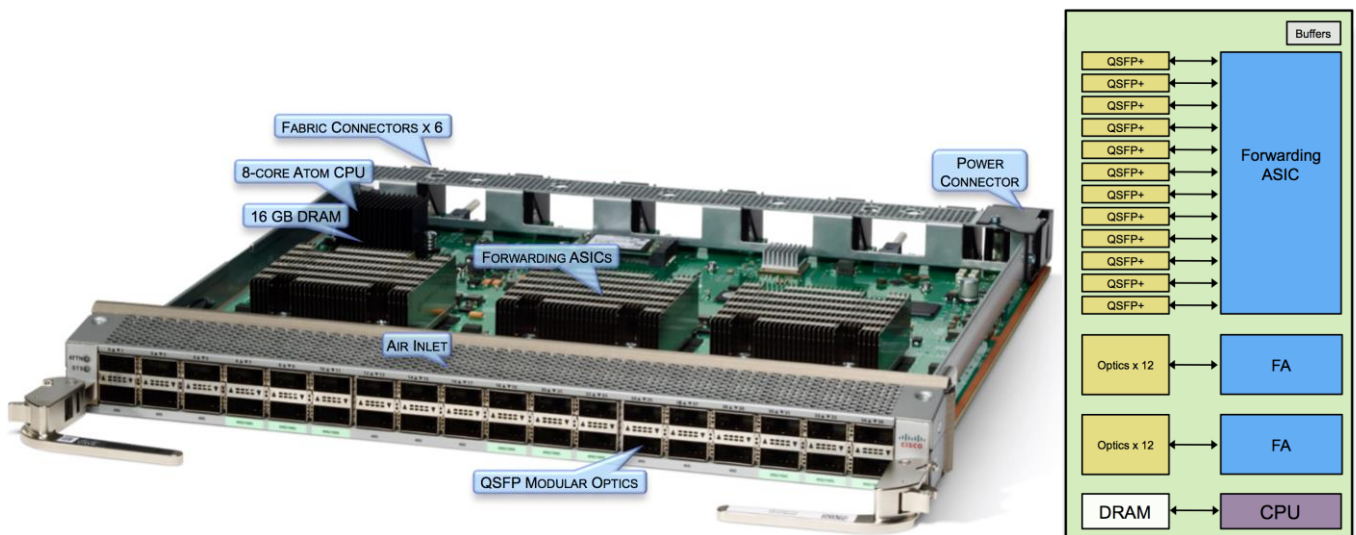

Figure 14- NCS 5500 18x 100G + 18x 40G Line Card

This line card delivers up to 2,160 million packets per second (Mpps) of distributed forwarding and up to 2.16Tbps of data throughput. NCS 5500 18x 100G + 18x 40G line card contains three forwarding ASICs, each offering 720Gbps of bandwidth with 720Mpps of throughput. NCS 5500 18x 100G + 18x 40G line card on-chip tables provides a minimum of 256K IPv4 or 64K IPv6 routes (350K IPv4 or 160K IPv6 with Internet prefixes distribution); additionally the On-chip tables provides 750k for IPv4 /32 or /24 routes shared with MPLS and MAC addresses.

NC55-18H18F	Specifications
Ports	36x 40G QSFP Ports 18x 100G + 18x 40G QSFP Ports 144x 10G SFP Ports via Breakout
Forwarding ASICs	3 Forwarding ASICs x (720Gbps bandwidth each)
Resources	On-chip tables for a minimum of 256K IPv4 or 64K IPv6 routes (350K IPv4 or 160K IPv6 with internet distribution) On-chip tables for 750K IPv4 routes, MAC and MPLS labels
Buffers per Forwarding ASIC	16MB On-chip Buffers 4GB Off-chip Buffers
Packet Forwarding Rate	Up to 2,160 Mpps (3 x 720 Mpps)
Forwarding Throughput	1.44Tbps (36x 40G configuration) 2.52Tbps (18x 100G + 18x 40G configuration)
Latency	2 to 8 usec

Table 8- NCS 5500 18x 100G + 18x 40G Line Card Specifications

NCS 5500 24x 100G + 12x 40G Line Card

The NCS 5500 24x 100G + 12x 40G line card provides 24 ports of 100G/40G and 12 ports of 40G for a total of 36 ports. 24 of the 36 ports can be upgraded to 100GE through a license on a per-port basis. This line card uses QSFP28/QSFP+ form factor transceivers and can be used in any of the NCS 5500 Series modular chassis. This card provides the highest routing scale of the portfolio along with line rate performance on each port. The extended scale is achieved for FIB, ACL and QoS by utilizing a 10MB external-TCAM. This external-TCAM is used in addition to the On-Chip table. The Off-chip/external-TCAM provides up to 2M entries that can be shared between IPv4, IPv6 routes, ACL and QoS. The on-chip table provides 750k entries for IPv4 routes, MPLS Labels and MAC addresses. Globally, the system supports up to 2.75M prefixes.

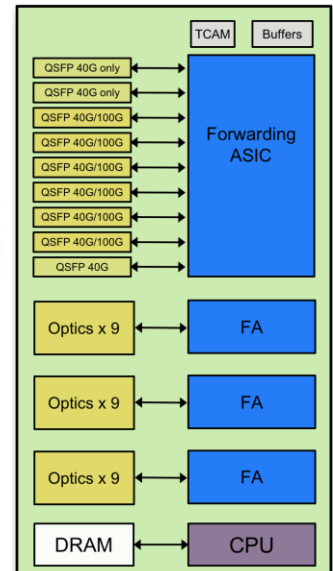
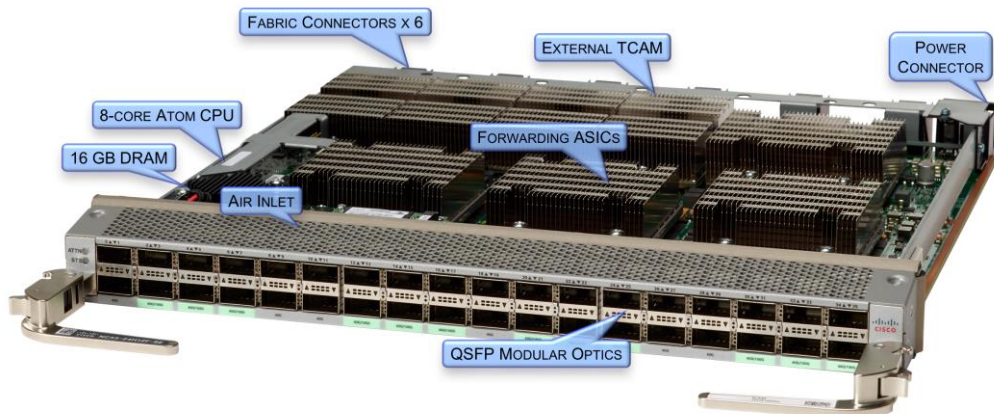

Figure 15- NCS 5500 24x 100G + 12x 40G Line Card

This line card delivers up to 2,400 million packets per second (Mpps) of distributed forwarding and up to 2.88Tbps of data throughput. NCS 5500 24x 100G + 12x 40G line card contains four forwarding ASICs, each offering 720Gbps of bandwidth with 600Mpps of throughput.

NC55-24H12F	Specifications
Ports	36x 40G QSFP Ports 24x 100G + 12x 40G QSFP Ports 144x 10G SFP Ports via Breakout
Forwarding ASICs	4 Forwarding ASICs x (720Gbps bandwidth each)
Resources	FIB scale up to 2M IPv4 or 1M IPv6 routes (FIB scale up to 2.75M IPv4 routes if combined with on-chip tables) On-chip tables for 750K IPv4 routes, MAC and labels
Buffers per Forwarding ASIC	16MB On-chip Buffers 4GB Off-chip Buffers
Packet Forwarding Rate	Up to 2,400 Mpps (4x 600 Mpps)
Forwarding Throughput	1.44Tbps (36x 40G configuration) 2.88Tbps (24x 100G + 12x 40G configuration)
Latency	2 to 8 usec

Table 8- NCS 5500 24x 100G + 12x 40G Line Card Specifications

Conclusion

The Network Convergence System 5500 Series modular platforms offers highest density of 10/40/100G ports forwarding at line rates with low-latency forwarding and lowest power consumption per Gigabit/sec for a fully loaded chassis.

The platform is highly reliable and resilient; its architecture is based on redundant route processors, system controllers, fan trays, fabric modules and power supplies.

The platform supports front to back airflow and platinum rated 91% plus efficient power supplies; these when combined with Cisco's innovative mid-plane less chassis design, results in benefits such as efficient power and cooling, increased meantime between failures and unrestricted scale for future growth.

NCS 5500 modular platform has base and scale models of line cards giving network operators the flexibility to choose based on their density, scale and cost needs. The Base version line card supports up to a million routes while the Scale version line card is available to cater to the requirements of multi-million routes and large ACLs. In addition to that all the line cards have on/off-ASICs buffers to provide deep queuing in case of network congestion.

NCS 5500 modular platform runs on Cisco IOS XR operating system, it is 64-bit Linux kernel based highly modular and fully distributed operating system that provides a virtualized environment to independently run system administration and routing functions on separate virtual containers. The IOS XR software also offers features that enable innovations such as automation, telemetry, application hosting and programmability.

Based on the hardware/software attributes and capabilities, NCS 5500 is an ideal platform to position in data centers, large enterprise, Web and service provider's WAN, Core and Aggregation networks to achieve efficient performance, highest density and scale for growth.