

Edgecore AS5915-18X

Disaggregated Cell Site Gateway Specification

Revision 1.2



OPEN
Compute Project

Revision History

| Revision | Date | Author | Description |
|----------|----------|------------|---------------------|
| 1.2 | 2/1/2021 | Matt Roman | Initial OCP Release |
| | | | |
| | | | |
| | | | |
| | | | |
| | | | |
| | | | |
| | | | |

Contents

| | |
|---------------------------------|----|
| Revision History..... | 2 |
| Licenses | 5 |
| Scope..... | 7 |
| Overview | 7 |
| Environmental..... | 7 |
| Timing support..... | 7 |
| Switch Silicon | 7 |
| Physical Overview | 8 |
| Front View..... | 8 |
| Rear View | 8 |
| Dimensions..... | 9 |
| Top View..... | 9 |
| Network / Timing Port LEDs..... | 10 |
| System LEDs | 11 |
| Console Port..... | 12 |
| System Overview: | 13 |
| Main PCB Block Diagram | 13 |
| CPU Module block diagram..... | 14 |
| PCB Board Set..... | 15 |
| Main board PCB Dimension | 15 |
| Placement Main board:..... | 16 |
| CPU Board Dimension | 17 |
| Placement CPU Board | 17 |
| Mechanical..... | 18 |
| Cooling Method | 18 |
| FAN characteristics: | 19 |
| Power Supplies..... | 22 |
| Pinout&DC inlet connector | 22 |

| | |
|------------------------------------|----|
| MISC Push Button | 23 |
| I2C Diagram..... | 24 |
| BCM88272 Serdes Mapping..... | 25 |
| Broadcom 54140 PHY | 26 |
| PHY Features | 27 |
| System CPLDs and FPGA | 27 |
| Specifications and Standards | 29 |
| Software Support | 30 |
| BIOS support..... | 30 |
| ONIE | 30 |
| Open Network Linux..... | 30 |

Licenses

All semiconductor devices that may be referred to in this specification, or required to manufacture products described in this specification, will be considered referenced only, and no intellectual property rights embodied in or covering such semiconductor devices shall be licensed as a result of this specification or such references. Notwithstanding anything to the contrary in the CLA, the licenses set forth therein do not apply to the intellectual property rights included in or related to the semi-conductor devices identifies in the specification. These references include without limitation the reference to devices listed below. For clarity, no patent claim that reads on such semiconductor devices will be considered a “Granted Claim” under the applicable Contributor License Agreement for this specification

| Feature | AS5915-18X |
|----------------|---|
| CPU sub-system | CPU: Intel ® Atom™ Processor C3308, 1.6GHz DDR SDRAM: 8GB x 1 2400MHz with ECC (SO-DIMM) DDR4 SPI Flash (Boot): 16MB x 2 M.2 SSD: 32GB MLC TPM: SLB 9665XT2.0 FW5.63 INFINEON |
| Management | UART RS232 console port (RJ45), Out-band Management Ethernet port (RJ45) |
| Timing | 1PPS IN and 1PPS OUT(SMB), 10MHz IN and 10MHz OUT (SMB), BITS (RJ45), ToD PPS (RJ45) |
| MAC | Broadcom BCM88272, 64Gbps full duplex switching |
| Ethernet Ports | 6x 10GE SFP+, 8x 1/2.5GE SFP and 4x 1GE RJ45 |
| CPLD | Altera 5M2210ZF324I5N |
| FPGA | Altera EP4CGX50CF23I7N |
| PSU | Max 180W output, DC to DC, 1+1 redundant load-sharing Ability to support AC to DC power supply 1+1 redundant in another SKU variant |
| Cooling | 4 pcs fixed 40mm x40mm x 28mm, 12V fans, support 3+1 redundancy mode Notes: The airflow is left to right from front ports view There is support for a removeable fan filter on the left side of the unit. |
| Dimension | L (Depth): 240mm W (Width): 440mm H (Height): 43.7mm [1RU tall] |

As of February 1, 2021 this specification is contributed under the OCP Contributor Licensing Agreement (OCP-CLA) by the following entities:
Acton Technology Corporation, through its subsidiary Edgecore Networks Corporation

Limitations of the OCP CLA license are noted below:
No Limitations

You can review the signed copies of the OCP-CLA for this specification on the OCP website. <http://www.opencompute.org/products/specsanddesign>
Usage of this specification is governed by the OCPHL permissive. You can review this license at <http://www.opencompute.org/participate/legal-documents/>

Your use of this Specification may be subject to other third-party rights. THIS SPECIFICATION IS PROVIDED "AS IS." The contributors expressly disclaim any warranties (express, implied, or otherwise), including implied warranties of merchantability, non-infringement, fitness for a particular purpose, or title, related to the Specification. The entire risk as to implementing or otherwise using the Specification is assumed by the Specification implementer and user. IN NO EVENT WILL ANY PARTY BE LIABLE TO ANY OTHER PARTY FOR LOST PROFITS OR ANY FORM OF INDIRECT, SPECIAL, INCIDENTAL, OR CONSEQUENTIAL DAMAGES OF ANY CHARACTER FROM ANY CAUSES OF ACTION OF ANY KIND WITH RESPECT TO THIS SPECIFICATION OR ITS GOVERNING AGREEMENT, WHETHER BASED ON BREACH OF CONTRACT, TORT (INCLUDING NEGLIGENCE), OR OTHERWISE, AND WHETHER OR NOT THE OTHER PARTY HAS BEEN ADVISED OF THE POSSIBILITY OF SUCH DAMAGE.

Scope

This document outlines the technical specifications for the Edgecore AS5915-18X Open Disaggregated Cell Site Gateway Platform contributed to Open Compute.

Overview

This document describes the technical specifications of the AS5915-18X Disaggregated Cell Site Gateway designed by Edgecore Networks Corporation. The AS5915-18X is a cost optimized design focused on the aggregation of 1G/10G cellular equipment in the mobile backhaul network. The AS5915-18X is capable of supporting a broad set of IEEE 1588 PTP/SyncE features geared towards 4G and 5G timing needs.

The AS5915-18X supports eighteen network ports as follows:

- Six ports 10GE SFP+ interface operable in 1G/2.5G SFP as well.
- Eight ports 1/2.5G SFP interface.
- Four ports 1G RJ45 interface.

All network interface ports including the RJ45 support PTP and SyncE timing synchronization.

The AS5915-18X utilizes the Broadcom BCM88272 switching silicon and supports traditional features found in Telco switches such as:

- Deep Packet buffering.
- Ability to support a full set of SyncE/1588 timing synchronization functions.
- Support for installment in non-temperature controlled environments.
- Support a modular CPU card that allows flexibility in the CPU and/or memory configurations that can be offered.

Environmental

The AS5915-18X is designed for outside plant deployments in non-temperature controlled environments and supports deployment in operational environments ranging in temperature from -40C to +70C.

Timing support

The AS5915-18X supports a wide range of SyncE/1588 support including Boundary, Ordinary, and Transparent Clock support. The AS5915-18X supports timing ports such as BITS, TOD, and 1PPS and 10Mhz in/out. The timing synchronization for PTP and SyncE is also capable of being transmitted over all the line interfaces, such as the SFP+ and SFP and 1G RJ45 ports.

Switch Silicon

The AS5915-18X utilizes the Broadcom BCM88272 “Qumran-UX” switching silicon. This solution provides support for deep routing tables, large number virtual output queues for QOS, and external expandable packet buffering. The AS5915-18X is populated 4GB of external packet buffering supported by the BCM88272.

Physical Overview

Front View

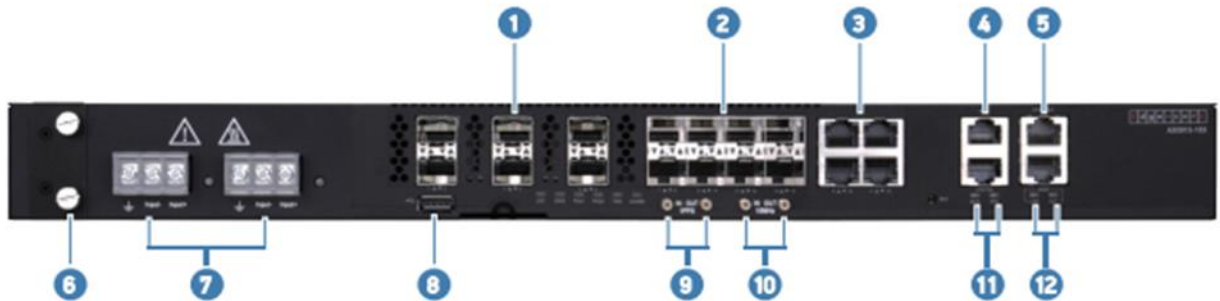

| Description | |
|-------------|------------------------------|
| 1 | 10G SFP+ ports |
| 2 | 1G SFP ports |
| 3 | 1G RJ-45 ports |
| 4 | BITS port |
| 5 | 1G RJ-45 console port |
| 6 | Filter Slot (Optional) |
| 7 | PSU 1/PSU 2 (fixed) |
| 8 | USB 2.0 |
| 9 | 1pps Input/Output |
| 10 | 10MHz Input/Output |
| 11 | TOD/1PPS RJ-45 port |
| 12 | Management RJ-45 port (MGMT) |

Rear View



The rear view of AS5915-18X includes the following key components:

- Chassis Grounding Location

Dimensions

| Category | Millimeters |
|----------------|--------------------|
| Length (depth) | 240mm |
| Width | 440mm |
| Height | 43.25±0.5 mm [1RU] |



Top View

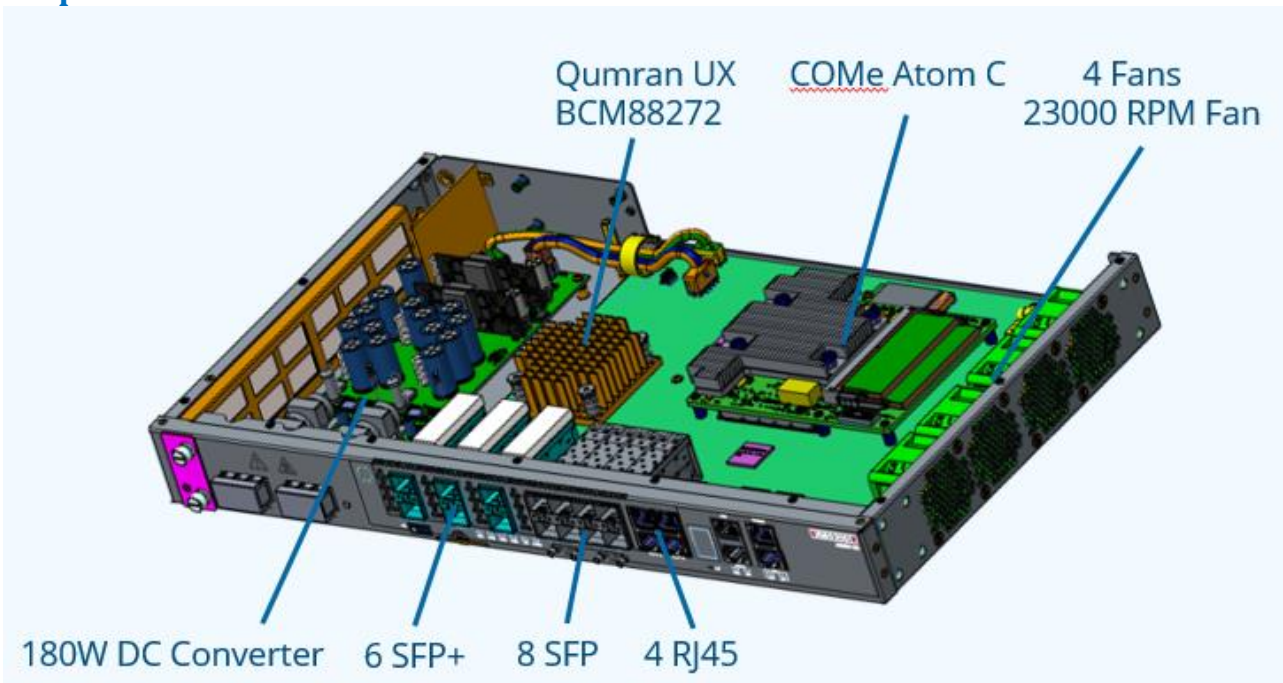

Network / Timing Port LEDs

Each network port has dedicated LEDs to indicate link status and activity. The ToD and BITS ports each have a dedicated LED to indicate Link status.

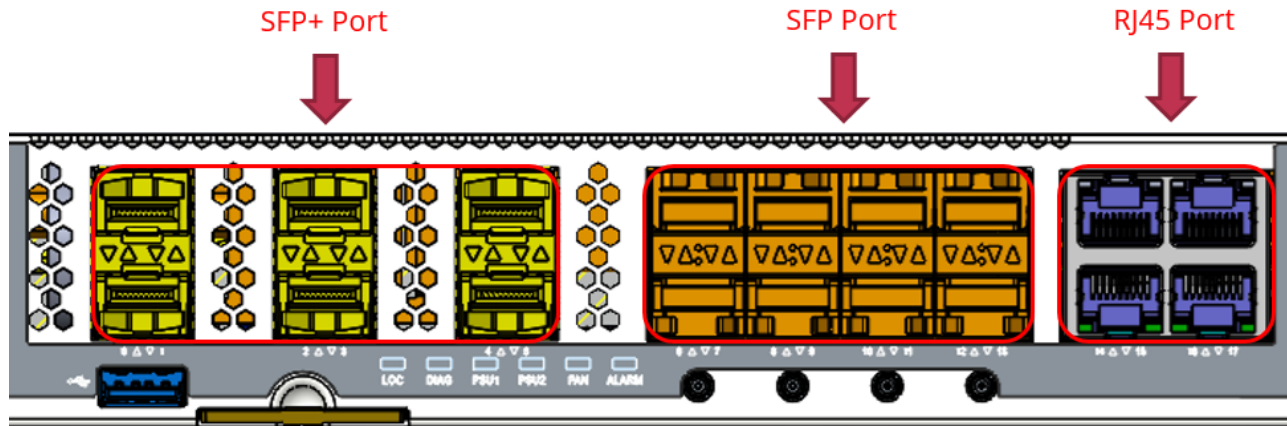

| LED | CONDITION | STATUS |
|--|----------------|---|
| SFP+ Port LED (Port0 to Port5) (Link) | On/Green | SFP+ port has a valid link and the solid green to indicate link. |
| | Off | There is no link on the port. |
| SFP+ Port LED (Port0 to Port5) (Activity) | Flashing/Green | SFP+ port has a valid activity at 10G mode and the flashing green to indicate 10G activity. |
| | Flashing/Amber | SFP+ port has a valid activity at 1G mode and the flashing blue to indicate 1G activity. |
| | Off | There is no activity on the port. |
| SFP Port LED (Port0 to Port 7) (Link) | On/Green | SFP port has a valid link and the solid green to indicate link. |
| | Off | There is no link on the port. |
| SFP Port LED (Port0 to Port7) (Activity) | Flashing/Green | SFP port has a valid activity at 1G mode and the flashing green to indicate 1G activity. |
| | Flashing/Amber | SFP port has a valid activity at 2.5G mode and flashing green to indicate 2.5G activity. |
| | Off | There is no activity on the port. |
| RJ45 Port LED (Port0 to Port3) (Link) | On/Green | Port has a valid link |
| | Off | There is no link on the port. |
| RJ45 Port LED (Port0 to Port3) (Activity) | Flashing/Green | Flashing indicates activity. |
| | Off | There is no activity on the port. |

| | | |
|--------------------------|-------------------|--|
| MGMT Port LED (Link) | On/Green | Port has a valid link at 1G mode. |
| | Off | There is no link at 1G or link at 10M/100M mode. |
| MGMT Port LED (Activity) | On/Green | Link at 10M/100M/1G mode. |
| | Flashing/Green | Flashing indicates activity. |
| | Off | There is no link/activity on the port. |
| ToD Status LED | On/Flashing Green | ToD port has an activity and the flashing to indicate activity. |
| | Off | There is no link on the port. |
| BITS Status LED | On/Flashing Green | Bits port has an activity and the flashing to indicate activity. |
| | Off | There is no link on the port. |
| | Off | There is no link on the port. |

System LEDs

The system LEDs are used to indicate the status of power and system.



| LABEL | COLOR | DESCRIPTION |
|---|-------------|--|
| PSU1 (PSU outputs 12V from 1 st DC input connector) | Green | This 12V is operating normally. |
| | Amber | PWR present but not power on or this power is fault. |
| | Off | Power supply not present. |
| PSU2 (PSU outputs 12V from 2 nd DC input connector) | Green | This 12V is operating normally. |
| | Amber | PWR present but not power on or this power is fault. |
| | Off | Power supply not present. |
| DIAG (Diagnostic) | Green | System self-diagnostic test successfully completed. |
| | Green Blink | System self-diagnostic test is in progress |
| | Amber | System self-diagnostic test has detected a fault. |
| FAN | Green | System fans operating normally. |
| | Green Blink | System fans are power off when ambient temperature is less than 10 degree C. |

| | | |
|------|---------------|--|
| | Amber | System FAN tray present but is fault. |
| ALRM | Green | System is operating normally. |
| | Red | System is in alarm state. |
| LOC | Blue Flashing | Flashing by remote management command. Assists the technician in finding the right device for service in the rack. |
| | OFF | Not a particular switch that technician need to find |

Console Port

The console port interface conforms to the RJ45 electrical specification.

The interface supports asynchronous mode with default eight data bits, one stop bit, and no parity.

The unit will operate at any one of the following baud rates:

- 9600, 19200, 38400, 57600, **115200 (Default)**

| Pin number | Pin name | Pin number | Pin name |
|------------|----------|------------|----------|
| 1 | RTS | 2 | UART_TXD |
| 3 | | 4 | |
| 5 | GND | 6 | UART_RxD |
| 7 | | 8 | CTS |

System Overview:

Main PCB Block Diagram

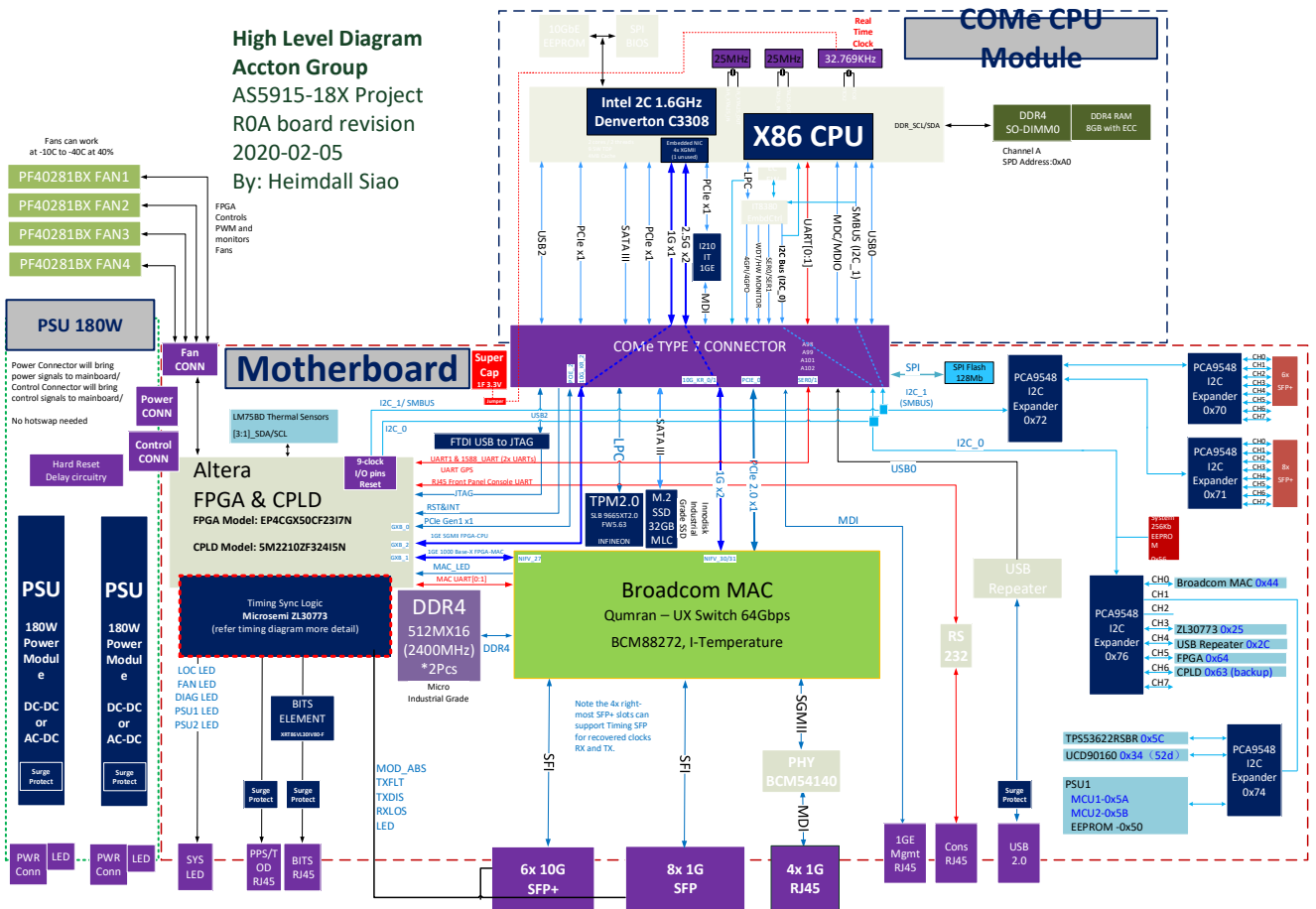

CPU Module block diagram

Atom C Series

COM Express*Type
7 Compact Module 125x95mm

AT / ATX Mode

12VDC+/-20%

-40° C ~ +85° C

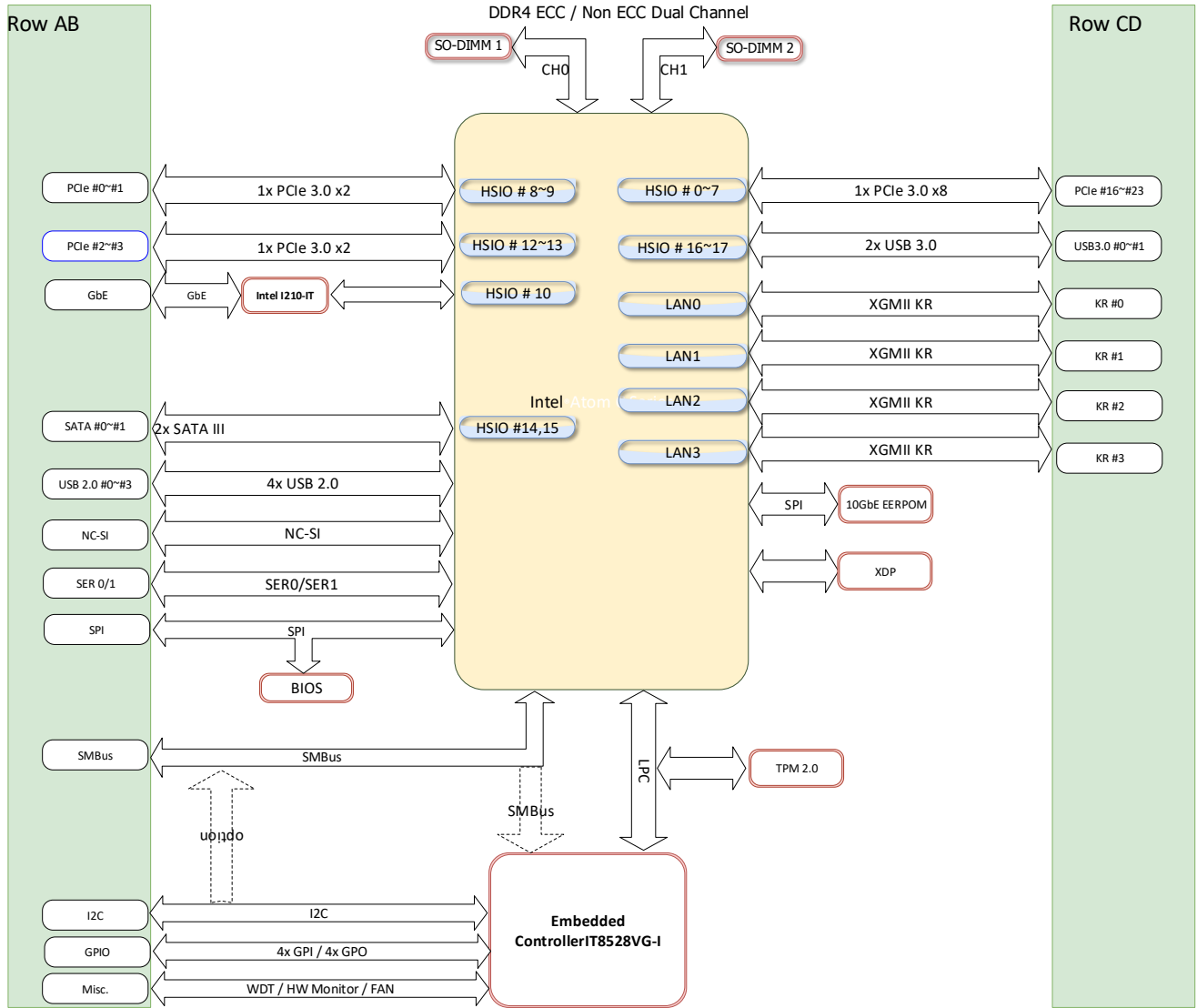

Placement Main board:

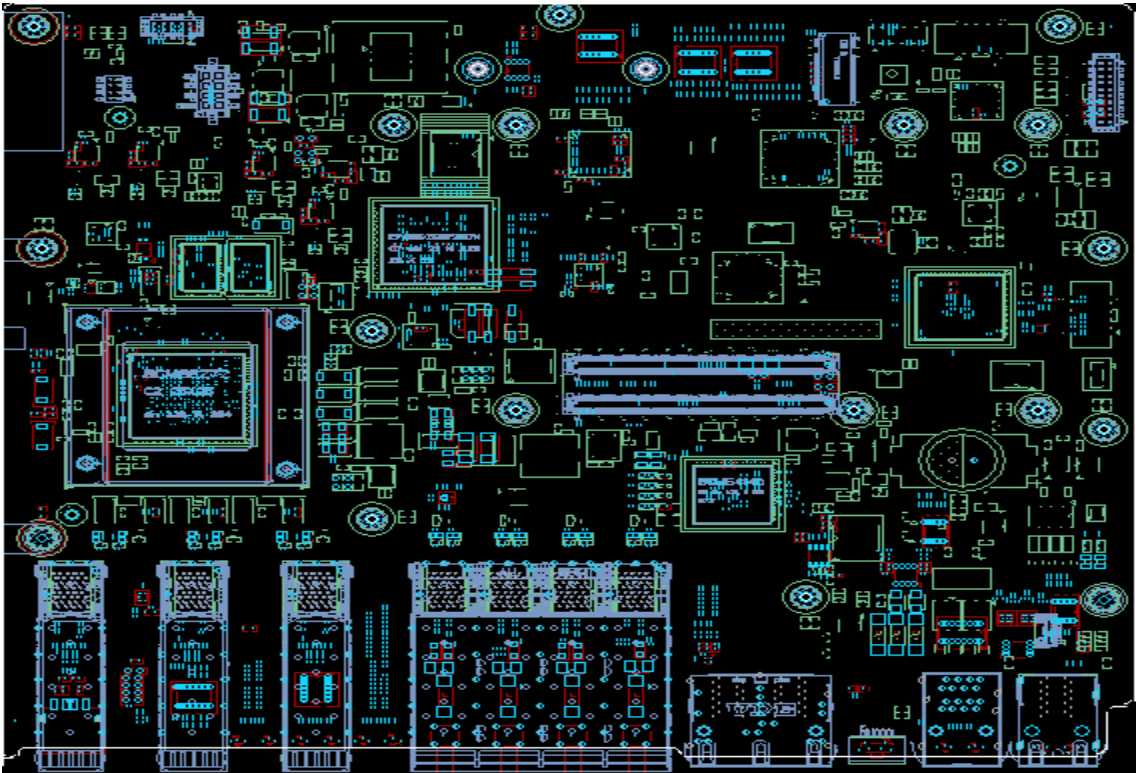
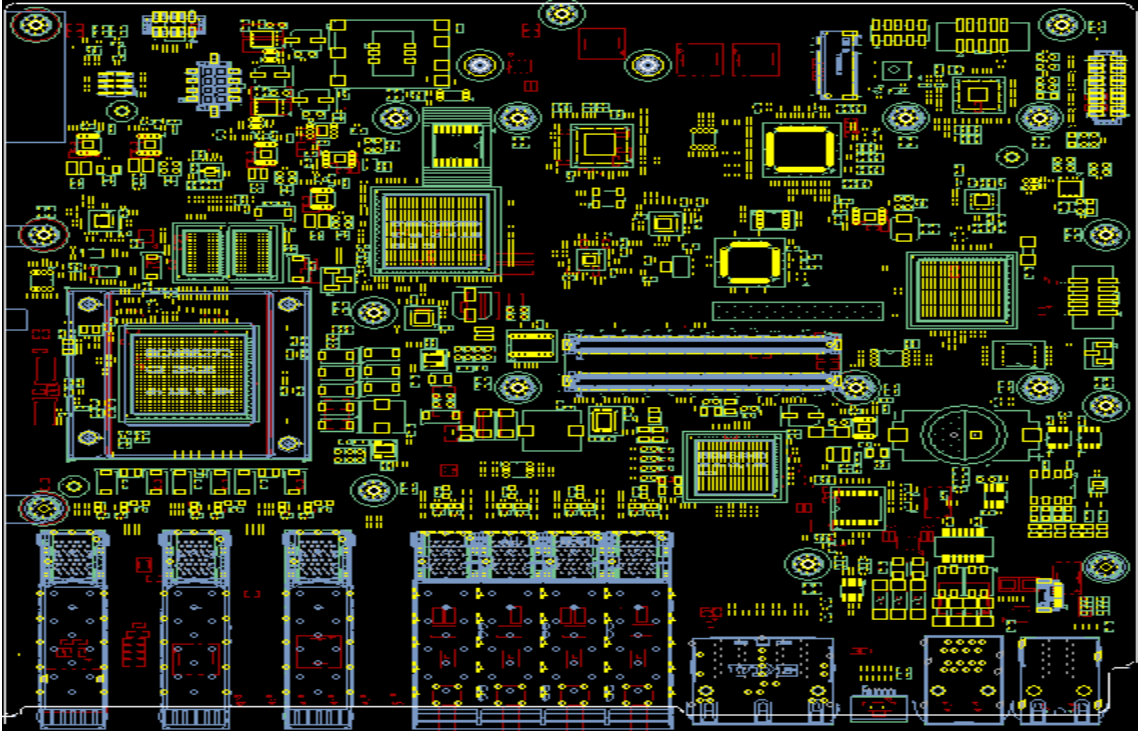

Mainboard TOP/Bottom PCB Placement

CPU Board Dimension

CPU board_L x W = 125mm x 95mm

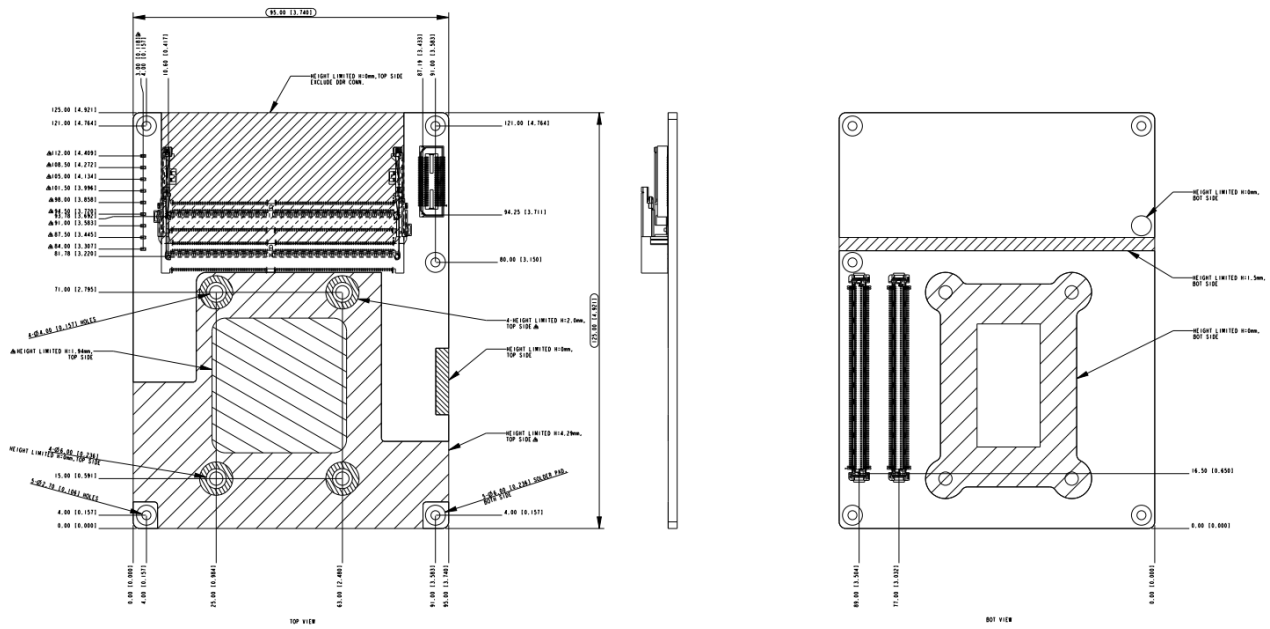

Placement CPU Board

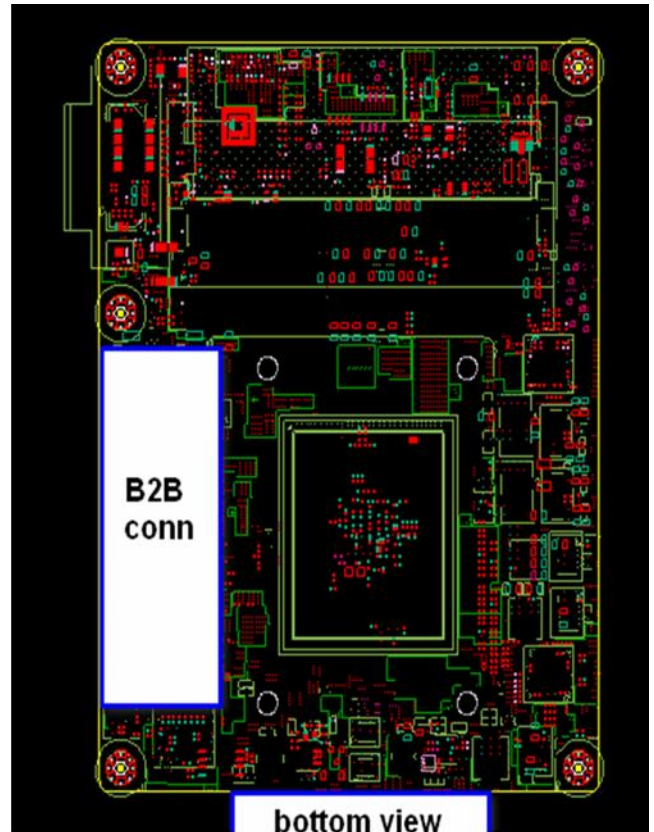
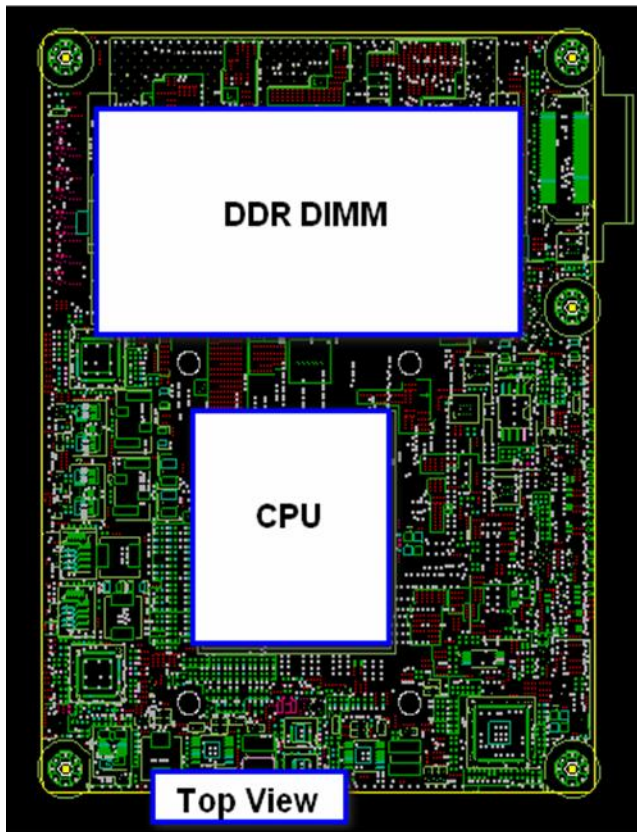

Mechanical

Mechanical Dimension

Height: 43.7±0.5mm (1.720472 ± 0.196inch)

Width: 440.0±0.5mm (17.322834 ± 0.0196inch)

Depth: 240±0.5mm (9.448188 ± 0.0196inch)

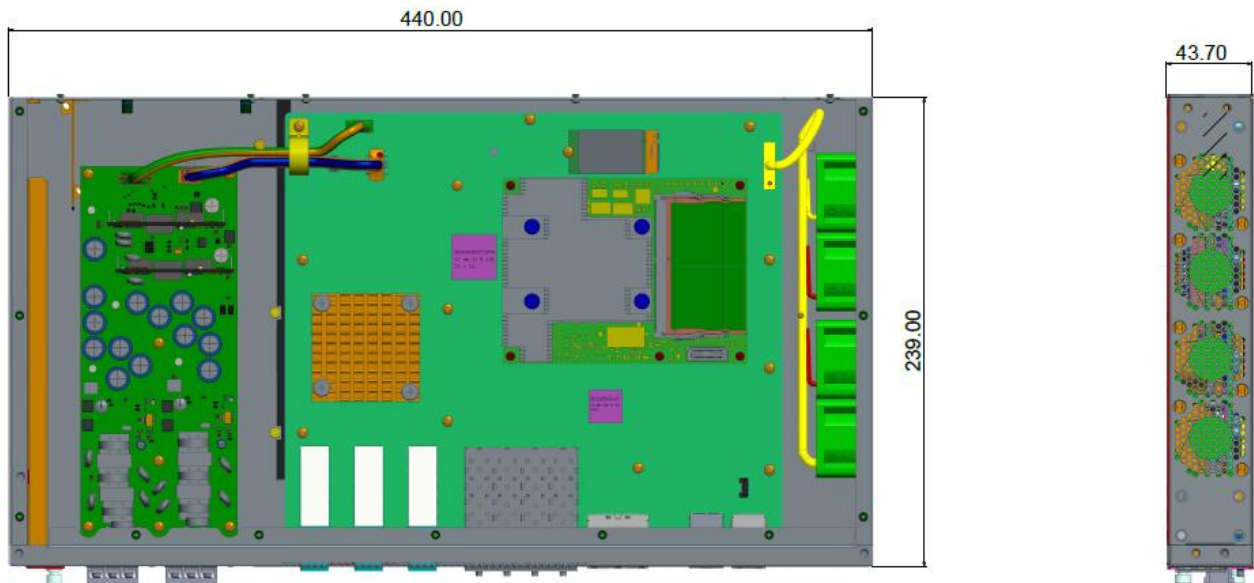

Cooling Method

AS5915-18X system supports four fan modules with Left to right airflow fan modules. The system supports left to right airflow direction

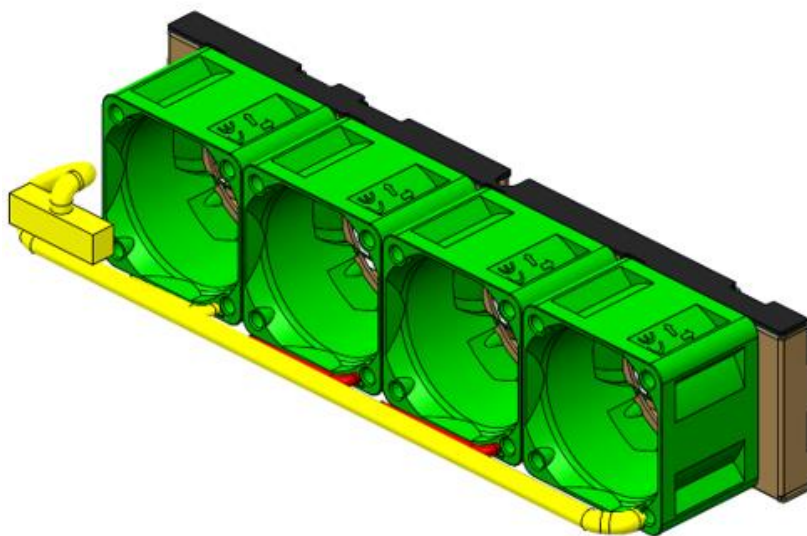

FAN characteristics:

| ITEM | DESCRIPTION | |
|-------------------------------------|---|----------------------|
| | 單體 | 合體 |
| RATED VOLTAGE | 12 VDC | |
| OPERATING VOLTAGE | 10.2 ~ 13.2 VDC | |
| STARTING VOLTAGE | 10.2 VDC (POWER ON/OFF AT 25°C) | |
| RATED CURRENT (AVG.) | 1.150 / MAX. 1.323 A | 2.300 / MAX. 2.645 A |
| RATED POWER (AVG.) | 13.80 / MAX. 15.88 W | 27.60 / MAX. 31.74 W |
| SAFETY POWER CONSUMPTION | 15.18 W | |
| RATED SPEED | 23000 RPM \pm 10% IN FREE AIR AT RATED VOLTAGE | |
| MAX AIRFLOW AT ZERO STATIC PRESSURE | 31.6 / MIN. 28.5 CFM | |
| MAX STATIC PRESSURE AT ZERO AIRFLOW | 3.25 / MIN. 2.48 inch-H ₂ O | |
| ACOUSTICAL NOISE (AVG.) | 62.0 / MAX. 68.1 dB(A) | |
| INSULATION TYPE | UL CLASS A | |
| INSULATION RESISTANCE | 10M OHM MIN. AT 500 VDC BETWEEN FRAME AND (+) TERMINAL | |
| DIELECTRIC STRENGTH | 5mA MAX. AT AC 500 VAC 50/60 Hz ONE MINUTE BETWEEN FRAME AND (+) TERMINAL | |
| LIFE EXPECTANCY | 70,000 HOURS AT 40 °C WITH 15~65% RH. | |
| DIRECTION OF ROTATION | COUNTER-CLOCKWISE FROM BLADE SIDE | |

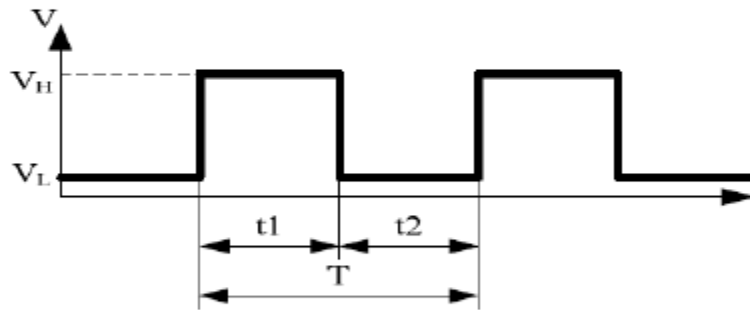
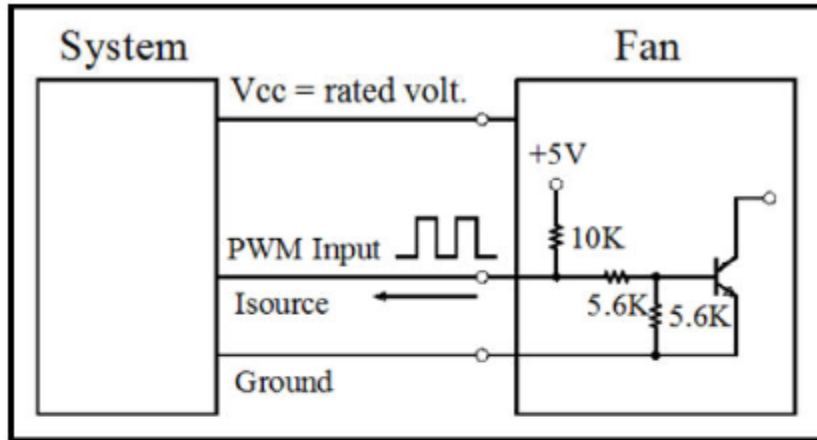

1. PERIOD :
$$T = \frac{1}{f_{PWM}} = t_1 + t_2(\text{sec})$$

2. DUTY CYCLE (D.C.) :
$$\frac{t_1}{t_1 + t_2} * 100 = \frac{t_1}{T} * 100(\%)$$

3. PWM DUTY CYCLE VS SPEED (AT $T_A = 25^\circ\text{C}$, $V_{CC} = 48\text{V}$, $f_{PWM} = 20\text{KHz}$)

| PWM Duty Cycle (%) | FAN Speed (R.P.M.) |
|--------------------|----------------------|
| 100 | 23000±10% |
| 50 | 15700±10% |
| 0 | 0 |

Fan PWM Control Signal

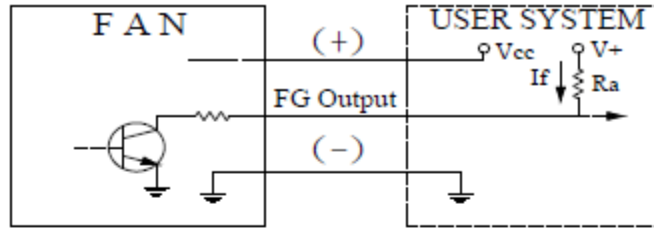

$$*Ra \geq V^+ / If (\max)$$

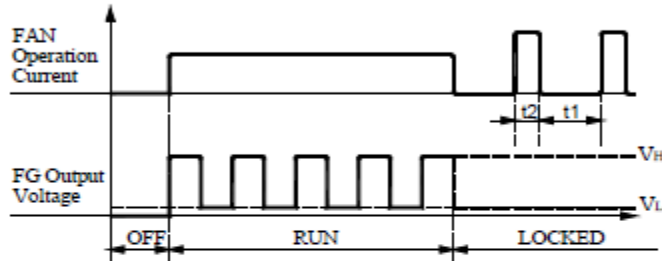

★ Electrical Characteristics : (at Ta = 25°C , Vcc = 12V)

| Parameter | Ratings | | | Unit |
|------------------------|---------|------|------|---------|
| | min. | typ. | max. | |
| FG Supply Voltage (V+) | -- | -- | 13.2 | Voltage |
| FG Output Current (If) | -- | -- | 5 | mA |
| FG Output (VL) | -- | -- | 0.6 | Voltage |
| FG Output (VH) | -- | -- | V+ | Voltage |
| t1 (OFF) | -- | -- | 9 | μs |
| t2 (ON) | -- | -- | 600 | mS |

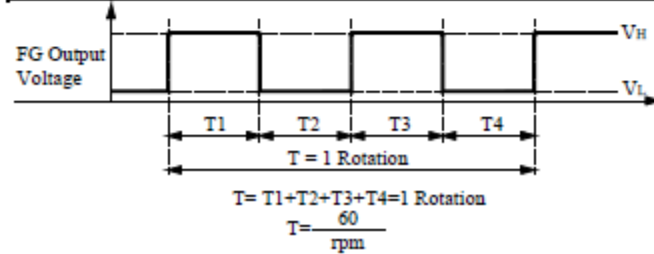

Fan Frequency Generator Signal

Power Supplies

The AS591518X system supports fixed redundant DC-DC power supply modules. The power supply supports up to 180Watt of output.

- **Model Number: CRXT-C8T120**
- **Vendor: Belfuse**
- **Input Voltage: 36V to 72 VDC**
- **Output Voltage: 12 VDC**
- **Max Output Current: 15A**
- **Max Power: 180W**
- **Typical Efficiency: 92%**

Pinout&DC inlet connector

The power module pin definitions are as below.

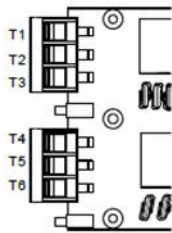

Figure 21. Input connector

| Pins | Function |
|------|-------------|
| T1 | PSU1 Earth |
| T2 | PSU1 Input- |
| T3 | PSU1 Input+ |
| T4 | PSU2 Earth |
| T5 | PSU2 Input- |
| T6 | PSU2 Input+ |

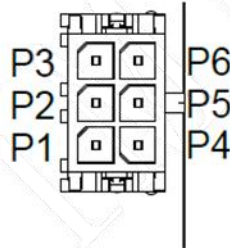

Figure 22. Output power connector

| Pins | Function |
|------|----------|
| P1 | Vout+ |
| P2 | Vout+ |
| P3 | Vout+ |
| P4 | Vout- |
| P5 | Vout- |
| P6 | Vout- |

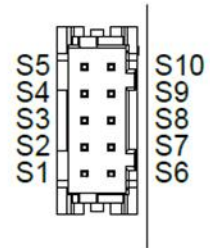

Figure 23. Output signal connector

| Pins | Function |
|------|------------|
| S1 | PS1_PG |
| S2 | PS2_PG |
| S3 | SCL |
| S4 | SDA |
| S5 | Alert |
| S6 | PS_ON1_L |
| S7 | RESET2_L |
| S8 | RESET1_L |
| S9 | PS_ON2_L |
| S10 | GND(Vout-) |

MISC Push Button

The AS5915-18X has two push buttons, one is accessible through the front panel for manual H/W reset function used and resets the entire system.

The other push button is for R&D debug purposes and located on the main PCB.

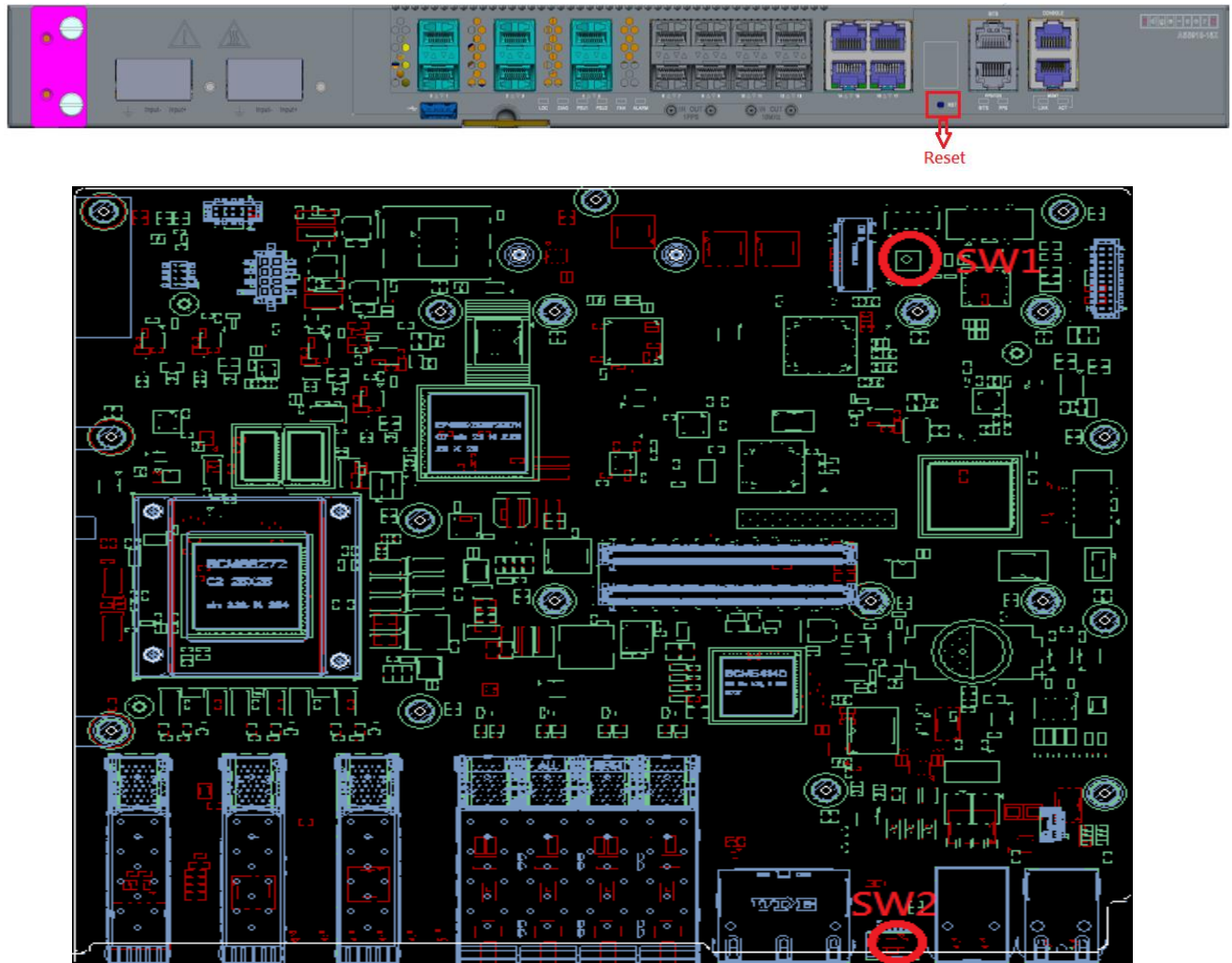

BCM88272 Serdes Mapping

The AS5915-18X allocates the BCM88272 network interface block as shown in the table below.

Table 1 NIF Mapping Table

| PM# | Interface | SFP+/SFP/BCM54 140/FPGA/CPU | Physical Port | Logical Port | MAC | | | |
|---------|-----------|--------------------------------|------------------|-----------------|----------|-----------------|-----------------|-------------------|
| | | | | | Device | Lane | Interface | Note |
| PM10-0 | SerDes | SFP+ | 3 | | BCM88272 | 0 | NIFE_TX[00]_P/N | |
| | | | | | | | NIFE_RX[00]_P/N | |
| | SerDes | SFP+ | 4 | | BCM88272 | 1 | NIFE_TX[01]_P/N | |
| | | | | | | | NIFE_RX[01]_P/N | |
| | SerDes | SFP+ | 5 | | BCM88272 | 2 | NIFE_TX[02]_P/N | |
| | | | | | | | NIFE_RX[02]_P/N | |
| | SerDes | SFP+ | 6 | | BCM88272 | 3 | NIFE_TX[03]_P/N | |
| | | | | | | | NIFE_RX[03]_P/N | |
| PM10-1 | SerDes | SFP+ | 1 | | BCM88272 | 4 | NIFE_TX[04]_P/N | |
| | | | | | | | NIFE_RX[04]_P/N | |
| | SerDes | SFP+ | 2 | | BCM88272 | 5 | NIFE_TX[05]_P/N | |
| | | | | | | | NIFE_RX[05]_P/N | |
| | SerDes | SFP+ | 7 | | BCM88270 | 6 | NIFE_TX[06]_P/N | For future use |
| | | | | | | | NIFE_RX[06]_P/N | |
| | SerDes | SFP+ | 8 | | BCM88270 | 7 | NIFE_TX[07]_P/N | For future use |
| | | | | | | | NIFE_RX[07]_P/N | |
| PM2.5-2 | SerDes | BCM54140 | 16 | | BCM88272 | 8 | NIFV_TX[08]_P/N | PHY address #1 |
| | | | | | | | NIFV_RX[08]_P/N | |
| | SerDes | BCM54140 | 15 | | BCM88272 | 9 | NIFV_TX[09]_P/N | PHY address #2 |
| | | | | | | | NIFV_RX[09]_P/N | |
| | SerDes | BCM54140 | 18 | | BCM88272 | 10 | NIFV_TX[10]_P/N | PHY address #3 |
| | | | | | | | NIFV_RX[10]_P/N | |
| | SerDes | BCM54140 | 17 | | BCM88272 | 11 | NIFV_TX[11]_P/N | PHY address #4 |
| | | | | | | | NIFV_RX[11]_P/N | |
| PM2.5-3 | SerDes | SFP | 14 | | BCM88272 | 12 | NIFV_TX[12]_P/N | |
| | | | | | | | NIFV_RX[12]_P/N | |
| | SerDes | SFP | 13 | | BCM88272 | 13 | NIFV_TX[13]_P/N | |
| | | | | | | | NIFV_RX[13]_P/N | |
| | SerDes | SFP | 12 | | BCM88272 | 14 | NIFV_TX[14]_P/N | |
| | | | | | | | NIFV_RX[14]_P/N | |
| | SerDes | SFP | 11 | | BCM88272 | 15 | NIFV_TX[15]_P/N | |
| | | | | | | | NIFV_RX[15]_P/N | |
| PM2.5-4 | SerDes | SFP | 10 | | BCM88272 | 16 | NIFV_TX[16]_P/N | |
| | | | | | | | NIFV_RX[16]_P/N | |
| SerDes | SFP | 9 | | BCM88272 | 17 | NIFV_TX[17]_P/N | | |

| | | | | | | | | |
|---------|--------|------|---|--|----------|----|------------------------------------|-----------------|
| | | | | | | | NIFV_RX[17]_P/N | |
| | SerDes | SFP | 8 | | BCM88272 | 18 | NIFV_TX[18]_P/N NIFV_RX[18]_P/N | For current use |
| | SerDes | SFP | 7 | | BCM88272 | 19 | NIFV_TX[19]_P/N NIFV_RX[19]_P/N | For current use |
| PM2.5-6 | SerDes | FPGA | | | BCM88272 | 27 | NIFV_TX[27]_P/N NIFV_RX[27]_P/N | |
| PM2.5-7 | SerDes | CPU | | | BCM88272 | 30 | NIFE_TX[30]_P/N NIFE_RX[30]_P/N | |
| | SerDes | CPU | | | BCM88272 | 31 | NIFE_TX[31]_P/N NIFE_RX[31]_P/N | |

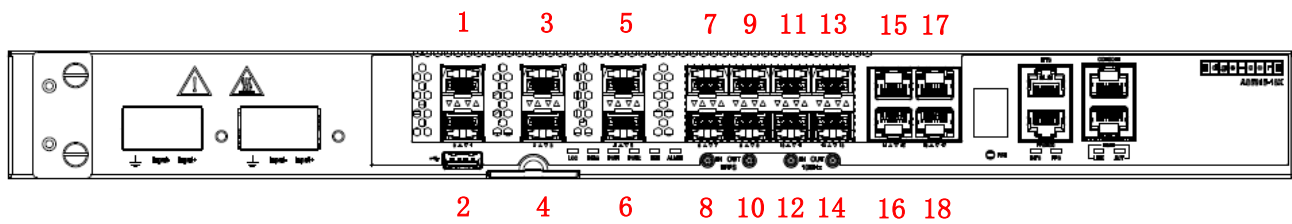

Broadcom 54140 PHY

The Broadcom BCM54140 is a fully integrated quad gigabit transceiver. This PHY is used to convert the SERDES from the Broadcom MAC ASIC to four 1G RJ45 on the front panel. The BCM54140 is designed to support SGMII and QSGMII industry standards. Designed for reliable operation over worst-case Category 5 cable plants, the BCM54140 automatically negotiates with any transceiver on the opposite end of the wire to agree on an operating speed. The PHY can also evaluate the condition of the twisted-pair wiring to ensure that the wiring can support operation at Gigabit speeds, and detect and correct most common wiring problems. The device continually monitors both the wiring and the opposing transceiver and alerts the system if it detects potential problems with reliable operation.

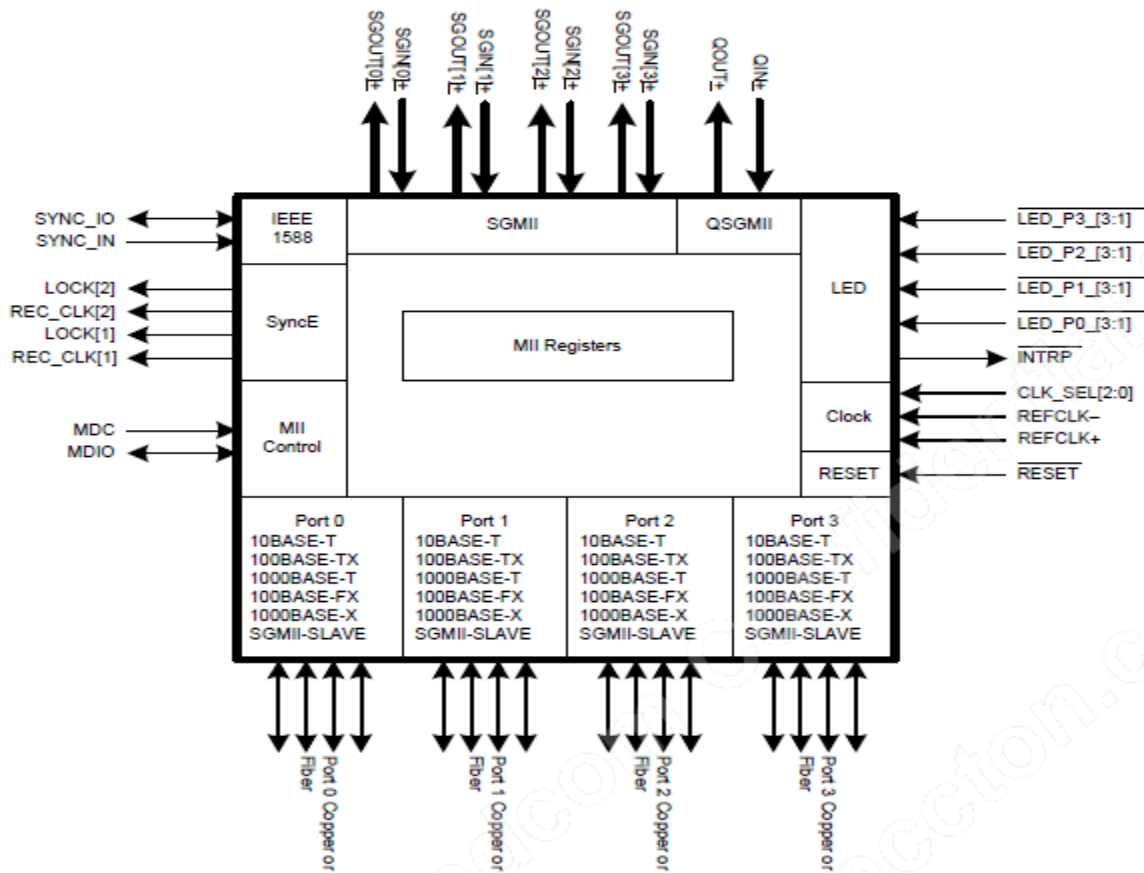

PHY Features

- Support for the following copper line interfaces:
 - ◆ 1000BASE-T, 100BASE-TX, and 10BASE-T
- Energy Efficient Ethernet (EEE) IEEE 802.3az
 - ◆ Support for native EEE MACs
 - ◆ Support for legacy non-EEE MACs using AutogrEEEn mode
- IEEE 1588v2-compliant
 - ◆ One-step clock or two-step clock
 - ◆ On-chip time stamping
- Synchronous Ethernet support
- Voltage and temperature monitors

System CPLDs and FPGA

This system has 1x CPLD and 1x FPGA.

1. The CPLD shows the network port LEDs, detects transceiver status, and handles fan speed adjustment of the system fans.
2. The FPGA handles initialization of various devices such as Zarlink PLL and BITS FRAMER and can also pull reset lines on I2C busses. The FPGA has PCIe access to the CPU

for configuration options. The FPGA is also responsible for controlling the timing system and various clocks go into and out of the FPGA.

The FPGA is on the motherboard with connections to CPU via I2C interface and I2C access address is 0x64. The following features are available with the FPGA:

- D2D Margin High/Low control (only for test)
- Thermal sensor read/write
- PSU Power On/Off control
- Reset and Interrupt
- Interface translation (I2C to SPI)
- UART selection
- 1588PTP

CPLD

The following features are available with the CPLD:

- FAN speed adjustment
- Fan detection
- SFP+ Port LED Link/Act indicates for Port 1 to Port 6
- SFP Port LED Link/Act indicates for Port 7 to Port 14
- RJ45 Port LED Link/Act indicates for Port 15 to Port 18
- SFP+ Port[0:5] & SFP Port[6:13] transceiver status detect
- I2C
- Reset

Specifications and Standards

- Reference Documents

- 1) ATT-TP-76200

Safety

- UL (CAN/CSA 22.2 No 60950-1 & UL60950-1)
- CB (IEC/EN60950-1)
- CCC (GB4943.1-2011)
- BSMI (CNS14336-1)

Electromagnetic Compatibility

- CE Mark
 - ◆ EN55032 Class A
 - ◆ EN55024(Immunity) for Information Technology Equipment
 - ◆ EN 61000-3-3
 - ◆ EN 61000-3-2
- FCC Title 47, Part 15, Subpart B Class A
- VCCI Class A
- CNS 13438 (BSMI)
- CCC (GB9254-2008)

Environmental

- Low-Temperature Exposure and Thermal Shock (packaged) : NEBS GR63-CORE ISSUE 4 , Section 4.1.1.1
- High Relative Humidity Exposure (Packaged) : NEBS GR63-CORE ISSUE 4 , Section 4.1.1.2
- High-Temperature Exposure and Thermal Shock (Packaged) : NEBS GR63-CORE ISSUE 4 , Section 4.1.1.3
- Operating Temperature and Relative Humidity : NEBS GR63-CORE ISSUE 4 , Section 4.1.2
- Altitude : NEBS GR63-CORE ISSUE 4 , Section 4.1.3
- Handling Drop Tests -Packaged Equipment : NEBS GR63-CORE ISSUE 4 , Section 4.3.1.1
- Unpackaged Equipment -Drop Tests (All Equipment) : NEBS GR63-CORE ISSUE 4 , Section 4.3.2
- Earthquake (10U Rack) : NEBS GR63-CORE ISSUE 4 , Section 4.4.1 (Zone4)
- Office Vibration Test Procedure; 90 minutes/axis (Stand & 42U Rack) : NEBS GR63-CORE ISSUE 4 , section 4.4.4
- Transportation Vibration-Packaged Equipment : NEBS GR63-CORE ISSUE 4 , section 4.4.5
- Acoustic noise : NEBS GR63-CORE ISSUE 4 , section 4.6
- Bump : IEC60068-2-29- packaged
- Shock : ETSI EN 300 019-2-3 -Operational Tests, Class T3.2 op

ROHS (6/6) Requirement

Restriction of Hazardous Substances (6/6):

Compliance with Environmental procedure 020499-00, primarily focused on Restriction of Hazardous Substances (ROHS Directive 2002/95/EC) and Waste Electrical and Electronic Equipment (WEEE Directive 2002/96/EC).

Software Support

AS5915-18X supports a base software package composed of the following components:

BIOS support

AS5915-18X supports AMI AptioV BIOS version A01 or greater with the x86 CPU module

ONIE

See <https://github.com/opencomputeproject/onie/tree/master/machine/accton> for the latest supported version

Open Network Linux

See <http://opennetlinux.org/> for latest supported version