

JUNKO ITÔ, YOSHIHISA KITAGAWA AND ARMIN MESTER

PROSODIC FAITHFULNESS AND CORRESPONDENCE:
EVIDENCE FROM A JAPANESE ARGOT*

This paper develops a comprehensive optimality-theoretic analysis of a Japanese reversing argot. Similar to other types of prosodic-morphological word formation, the argot shows the activation of constraints defining phonological unmarkedness. This manifests itself in the emergence of optimal prosodic form, within the limits imposed by a game-specific reversal requirement. The latter is formally characterized as Cross-Anchoring, a playful variation of the normal correspondence-theoretic anchoring constraints that are part of the phonological grammar. Under the combined pressure of Cross-Anchoring and high-ranking prosodic form constraints, the argot distorts each ordinary-language base word in the minimal way, otherwise echoing it as faithfully as possible. As an important theoretical result, the analysis presents empirical evidence that prosodic faithfulness needs to be gauged in terms of foot-structural roles and not (or not exclusively) in terms of whole foot-sized constituents. Overall, the study demonstrates that the notion of “minimal distortion” operative in argot formation is none else but the principle of minimal violation of a set of ranked constraints, the fundamental tenet of Optimality Theory.

1. INTRODUCTION

It is a common observation that social groups tend to set themselves apart from their surrounding society by developing group-specific jargons. The effect, intended or unintended, is that, by their lack of competence and fluency in the appropriate speech mannerisms, nonmembers are marked as outsiders. One form such a jargon can take is that of an argot – a secret or play language that systematically distorts the words of the vernacular, in a way transparent only to those who possess the key.

An argot of this kind, known as *zuuja-go* ‘jazz language, jazzese’, is widely used in Japanese jazz circles, from where it has spread to wider parts of the entertainment industry (*gyokai-kotoba* ‘show business talk’). Because of its relative complexity and the light it casts on issues in prosodic phonology (Selkirk (1984), Hyman (1985), Nespov and Vogel (1986), Itô (1986, 1989), Pierrehumbert and Beckman (1988), Hayes (1989, 1995), Inkelas (1989), etc.) and Prosodic Morphology (McCarthy and Prince (1986) et seq.), *zujago* (ZG) has received significant attention in the recent linguistic literature, beginning with Kitagawa (1984) and the thorough and carefully argued analysis in Tateishi (1989); later treatments include Poser (1990), Itô and Mester (1991), Perlmutter (1992), and Itô, Kitagawa, and Mester (1992). Taking up the last-mentioned work (henceforth IKM (1992))

and cast within the framework of Optimality Theory (Prince and Smolensky (1993)), the present study extends the empirical scope and accuracy of the analysis.¹ Similar to other play languages (such as Pig Latin, see Bagemihl (1989) for general discussion), the essence of the argot consists in a reversal of phonological material of the base form. The examples in (1) give the flavor of ZG – of the way it is used, and of the variety of reversal types encountered.²

- (1) a. batsugUN -no fumeN ‘fantastic score’
 ↓_{ZG} ↓_{ZG}
 guNbatsu -no meNfu
- b. piano -no shikake ‘the response-demanding
 ↓_{ZG} ↓_{ZG} call by the piano’
 yanopi -no kakeshi (Yamashita (1977, 28))
- c. tsu: -ka kichigai -ka ‘expert or maniac’
 ↓_{ZG} ↓_{ZG}
 u:tsu -ka gaikichi -ka
- d. mazui ko:hi: -da na: ‘this is bad coffee’
 ↓_{ZG} ↓_{ZG}
 zuima -na hi:ko: -da na:
- e. nomi -ni iku ‘go for a drink’
 ↓_{ZG}
 mi:no-ni iku (Yazawa (1980, 230))
- f. mane:ja:-wa bikkuri - gyo:teN ‘the manager (was) stunned
 ↓_{ZG} ↓_{ZG} ↓_{ZG} out of his wits’
 ja:mane-wa kuribitsu- teN gyo: (Yamashita (1977, 214))

In some way or other, all ZG-formations follow this pattern.³ As phonological material gets exchanged, certain modifications take place and are in fact obligatory; but behind all these permutations and modifications, fundamental properties of the base form are always preserved in successful ZG-forms. It is this faithfulness to their base form that makes the ZG-game interesting from a linguistic point of view and invites an analysis in terms of Optimality Theory (Prince and Smolensky (1993)). The essence of the argot formation can be understood as analyzing words into two parts and switching their order and is illustrated by simple examples in (2).

(2)

<i>Base</i>		⇒	<i>Argot</i>		
⏟			⏟		
PrWd			PrWd		
α	β		β	α	
ko:	hi:		hi:	ko:	'coffee'
fu	meN		meN	fu	'musical score'
ku	suri		suri	ku	'drugs' (Yamashita (1977, 15))
kya	ku		ku:	kya	'audience' (Yamashita (1986, 266))
mane:	ja:		ja:	mane	'manager'

The point of ZG, the “fun of the game,” lies in a characteristic distortion of the input through reversal and further modifications. At the same time, the input form remains recoverable in spite of these distortions since a number of properties remain invariant in any ZG input-output mapping. To begin with, there is the rather straightforward fact that, although rearranged, the segmental contents of the input form is always preserved in the output (with very limited exceptions to be discussed later). A form like *hi:ko:* is ZG for *ko:hi:* ‘coffee’ and never for some segmentally totally different input (like *pose:doN* ‘Poseidon’). Considerably less obvious, but from a phonological perspective more interesting and revealing, is the fact that the prosodic shape of the output is not fixed by a single template (a hallmark of traditional prosodic-morphological analysis) but is rather determined by the prosodic markedness constraints, interacting with the requirement that a ZG-form should minimally deviate from its base, viz., the associated Japanese word. In earlier work, we formulated our basic conception of ZG, of its relation to Standard Japanese, and of the goals of an adequate analysis in the following way:

“As a language-related but ultimately non-linguistic game, it would be an error to try to ‘derive’ ZG-forms from their base forms by a step-by-step linguistic derivation. Rather, we have a set of correspondence rules connecting input and output, which are only partly linguistic.” (IKM (1992, 2))

Starting with this conception of the enterprise, the earlier study proposed a set of correspondence rules and principles designed to account for the systematic dependence of ZG-output on common-language input. Continuing in the same direction, the current work pursues the question of how this formal correspondence between ordinary Japanese and argot can be understood in a more precise manner. In this enterprise, the study makes use of recent advances in Optimality Theory (Prince and Smolensky (1993)), in particular of the powerful analytical methods of Correspondence Theory (McCarthy and Prince (1995)). As we will see, a correspondence-theoretic approach allows an analysis that is more exhaustive and more

principled than earlier proposals. At the same time, the linguistically highly unusual environment of the ZG argot presents an interesting test case for the overall theoretical framework and casts new light on a number of issues, including the notion of correspondence itself, anchoring, and prosodic faithfulness (in the latter case, supporting results independently reached in work by McCarthy (1995)).

The main formative principles underlying the argot can be summarized in the following points, which will be empirically substantiated and theoretically developed in the following sections:

- (3) a. *Reversal*: Argot words are reversals of their bases (in a sense to be made precise).
 b. *Template*: Argot words either have the form “F+F” (“foot+foot”) or the form “F+L” (“foot+light syllable”); nothing else is admitted.
 c. *Predictability*: Within the limits of (a), the prosodic type of an argot word is determined by the prosodic form of its base.
 d. *Preservation properties*: The mapping relation between base and argot form allows for weight adjustments (mora deletion and mora insertion) and segmental spreading, but not for segment deletion or segment insertion.
 e. *Null output*: As a consequence of (b) and (d), words of Japanese beyond a certain size limit do not have a corresponding argot form.

The templatic generalization noted in (3b) entails that, in terms of moraic length, there are only two classes of ZG-forms: (i) a 3-mora pattern (LLL or HL, see (4a)), and (ii) a 4-mora-pattern (LLLL, HLL, LLH, HH, see (4b)); we use “L” for “light syllable” and “H” for “heavy syllable”. Outputs shorter than 3 μ or longer than 4 μ are never encountered and are judged illformed – illformed, that is, as ZG-forms, even though possible words of Japanese.⁴

- (4) a. 3 μ argot structures:
- | | | |
|-----|--------|---------------------------------------|
| LLL | suriku | (from <i>kusuri</i> ‘medicine/drugs’) |
| HL | ke:sa | (from <i>sake</i> ‘rice wine’) |
| *LH | ∅ | |
- b. 4 μ argot structures:
- | | | |
|------|-----------|---------------------------------------|
| LLLL | sharukoma | (from <i>koma:sharu</i> ‘commercial’) |
| HLL | shi:taku | (from <i>takushi</i> : ‘taxi’) |
| LLH | tekoheN | (from <i>heNteko</i> ‘strange’) |
| HH | hi:ko: | (from <i>ko:hi</i> : ‘coffee’) |
| *LHL | ∅ | |

The regulation of output shapes goes beyond overall moraic size. As (4) also shows, not every combination of light and heavy syllables yielding a 3 μ - or 4 μ -word is admitted. In particular, a single initial L followed by H is ruled out, excluding the 3 μ *LH together with the 4 μ *LHL. As IKM (1992) observe, the restrictions on the patterns admitted as ZG forms can be understood as a markedness effect⁵ resulting from the fundamental principles underlying the prosodic organization of words and phrases in Japanese uncovered in numerous earlier studies (see Poser (1984b, 1990), Tateishi (1989), Itô (1990), Mester (1990), Itô and Mester (1992), Kubozono (1995), among others). In terms of the bimoraic trochaic foot realized either as H or as LL, a permissible ZG output is a concatenation of a bimoraic foot with either a following light syllable (F+L, (5a)) or another foot (F+F, (5b)).⁶

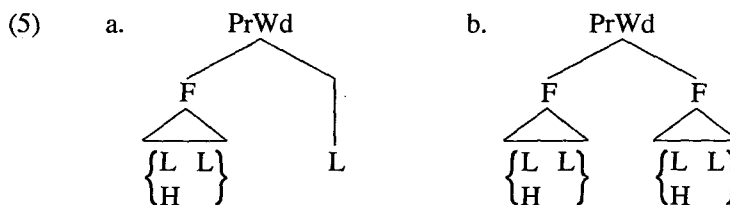

Viewed from the perspective of the prosodic grouping of syllables into bimoraic feet, a word-initial sequence LH amounts to a “prosodically trapped” L in initial position (Mester (1994)) – often a disfavored configuration since it has an unmetrified syllable with a disaligning effect (i.e., it prevents the coincidence of the initial word-edge with a foot-edge), as shown in (6).

(6) Prosodic shapes not permitted as ZG-outputs:

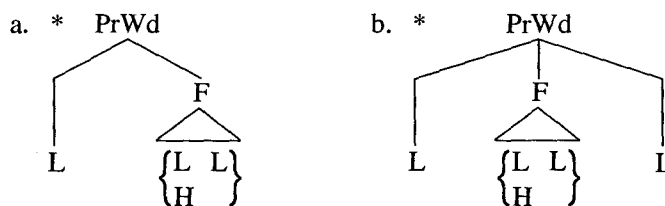

In contrast to this highly limited range of argot output shapes, the base forms that serve as inputs are not restricted in a similar way, neither in terms of the moraic length (cf. 2 μ -inputs like *sake* \Rightarrow_{ZG} *ke:sa* and 5 μ -inputs like *koma:sharu* \Rightarrow_{ZG} *sharukoma* in (4)), nor by the ban against initially trapped L (LH *fumeN* \Rightarrow_{ZG} *meNfu* ‘musical score’ and LHL *suto:bu* \Rightarrow_{ZG} *bu:suto* ‘stove’).

The prosodic form of ZG-outputs is thus limited to F+L (3μ) and F+F (4μ). Given these two possible outcomes and the additional fact that a large class of input types lacks an overt ZG correspondent altogether and instead leads to the null output (denoted by \emptyset in (7)), any analysis must address the question as to how the choice is made in each individual case. It is natural to hypothesize that the prosodic form of the output is a function of the prosodic form of the base – and this is indeed the case, as we will see. Base forms themselves need not conform to the 3μ and 4μ limitation; when they do not, their correspondents are made to fit the output shape limit. In addition, there is a third option: In broad outline, then, the mapping between Japanese base words and their correspondents in the argot has the form delineated in (7).

$$(7) \quad \begin{array}{ccc} \text{Base} & & \text{Argot} \\ x & \xrightarrow{\text{ZG}} & y = \begin{cases} \text{F+L} & \text{if } x = \dots \\ \text{F+F} & \text{if } x = \dots \\ \emptyset & \text{if } x = \dots \end{cases} \end{array}$$

The central analytical task now is to flesh out the function in (7), determining which input type maps onto which output type. While the fundamental generalizations here are relatively straightforward, some of the dependencies are rather intricate and present a considerable challenge to the analytical methods available. Our analysis will make heavy use of the specific conception of Input-Output relations developed by McCarthy and Prince (1995) under the name ‘‘Correspondence Theory,’’ a conception which diverges in interesting ways from the standard Parse/Fill model of Optimality Theory (Prince and Smolensky (1993)). In particular, correspondence is not limited to the familiar relation holding between (underlying) lexical input and surface output which has been central to the generative phonology enterprise, but provides a general framework encompassing other relations between linguistic structures, such as base-reduplicant (McCarthy and Prince (1994, 1995)) and base-truncatum (Benua (1995)), as well as other types of templatic morphology, including cases of prosodic circumscription (McCarthy (1995)). The ZG Correspondence model is depicted in (8) below. The input-output relation here does not hold between a lexical (underlying) representation and a surface representation but rather between two separate but related surface representations: base (the surface structure of the regular Japanese word) and its related argot (the surface structure of the ZG form).

(8) ZG Correspondence Model:

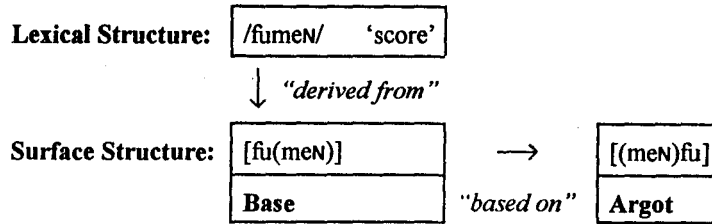

Surface-surface (base-argot) correspondence⁷ differs from lexical-surface correspondence in always linking two fully prosodified representations. As we will see, this has far-ranging consequences for the impact of prosodic faithfulness constraints on the selection of an argot output candidate for a given base. In order to distinguish between the (vertical) lexical-surface correspondence and the (horizontal) base-argot correspondence in (8), we recruit the traditional terminological distinction between grammatical derivation ('derived from') and surface analogy ('based on, built to') (see Hock (1986, 238–279)): The surface form is *derived from* the lexical input; the argot form is *based on* the base, etc.

This paper is organized as follows: Section 2 is a systematic presentation of the ZG-argot, organized in terms of the major generalizations about the shape of ZG-items and the mapping relations between these items and their bases. Section 3 introduces the basic prosodic constraints responsible for the output shape of ZG. Section 4 develops and motivates a cross-edge anchoring constraint which is responsible for the characteristic reversal properties of ZG-forms. Section 5 is concerned with prosodic faithfulness, that is, preservation of the input prosodic structure and prosodic roles in the ZG output. The paper concludes in section 6 by summarizing the analysis and pointing to further issues and remaining problems.

2. BASE-ARGOT MAPPING

Before proceeding to a full survey of the mapping relations between the ZG argot and their bases, it is important to be aware of the fact that the formation of ZG, while in many ways controlled by the phonological grammar, is in some respects also dependent on the Japanese kana writing system. This is most obvious in argot forms which diverge segmentally from their bases beyond what a mere reversal of phonological material would lead us to expect, as in the examples in (9) (where parentheses indicate bimoraic footing).

(9)

Base:	(bik) (kuri)	(hap) (pii)
Argot:	(kuri)(bitsu)	(pii) (hatsu)

‘surprised’ (in Yamashita (1977, 214)), ‘happy’ (in Yazawa (1980, 228))

When the first foot of the base form consists of a particular type of H, namely, a syllable closed by a geminate obstruent: $[(CVC_i)_o C_i \dots]$, a simple reversal would place this obstruent-closed syllable in word-final position: $* \dots (CVC)_o]$, an impossibility in Japanese phonotactics. In the actual ZG-form, we find (instead of a final H) an LL sequence, with the extra L realized as [tsu]. The somewhat drastic segmental change $[k, p] \rightarrow [tsu]$ finds a straightforward explanation when viewed from the perspective of the Japanese kana writing system. Moraically (and not segmentally) organized, the two kana systems, hiragana and katakana, constitute a rather precise prosodic notation system – certain complications aside, one mora corresponds to one kana, one foot to two consecutive kana. Consonant gemination is indicated by a small / ʷ / [tsu] preceding the kana whose onset consonant is geminated. As the katakana representation of the examples in (10) illustrates, ZG-reversal places the kana serving as the gemination marker, the small subscripted / ʷ /, in word final position, where it can no longer indicate gemination. It is therefore pronounced as a full-fledged kana (/ ʷ / [tsu]).

(10)

Base:	(b i k) (k u r i) (_ʷ) (ク リ)	(h a p) (p i :) (ハ) (ピ -)
Argot:	(k u r i) (b i t s u) (ク リ) (_ʷ)	(p i :) (h a t s u) (ピ -) (ハ)

With respect to individual orthography effects, some purely phonological account is of course easily imaginable. It is tempting, for example, to view the appearance of [tsu] in (10) as the emergence of the unmarked syllable, consisting of the unmarked vowel [u] preceded by the unmarked consonant [t], with allophonic affrication enforced by a high-ranking sequential constraint of Japanese (see Itô and Mester (1995a,b) for the latter). But such proposals have a ring of artificiality in comparison with the perfectly straightforward kana account,⁸ and they encounter apparently insurmountable difficulties when confronted with other examples that can only be made sense of by referring to the other central ingredient of the Japanese writing system, namely, the system of kanji (Chinese characters) and their readings (see (32) and (33) in section 2 for the relevant facts).

The ZG argot is a kind of word formation parasitizing the Japanese language, and it is not surprising that orthography (in particular, the prosodically sophisticated kana orthography⁹) plays a role. Other cases of orthographic influences in prosodically defined word formations are commonplace: Among the familiar monosyllabic English clippings (*Thomas* → *Tom*, *representative* → *rep*, etc.), one also encounters forms like *Pa[k] Bell* (from *Pa[s]ific Bell* – never **Pa[s] Bell*) and the syntacticians' *Spe[k]* (from *Spe[s]ifier*). A strictly phonological account might view the velar stop in such cases as the victorious emergence of a putative underlying /k/, here unaffected by an otherwise operative assibilation constraint (capturing the effects of Chomsky and Halle's (1968, 219–224) rule of "Velar Softening"). Imaginative as it is, such a scenario has little to recommend itself in the context of current theoretical phonology: It runs afoul of the otherwise lexically restricted and nonproductive nature of Velar Softening, and, more importantly, it is also incompatible with most versions of Optimality Theory adopting (some form of) lexicon optimization (see Prince and Smolensky (1993), Inkelas (1994b), and Itô, Mester and Padgett (1995) for discussion), where such abstract underlying forms are unavailable in otherwise nonalternating morphemes. What is going on in *Pac Bell*, we suggest, is not the re-emergence of a long-lost /k/ but rather a much more prosaic event: The default rule for the grapheme ⟨c⟩ in English spelling (namely: ⟨c⟩ ≡ /k/, see Carney (1994, 301–305) for an exhaustive survey) is applied to the orthographic representation of the clipped *Pac Bell*, resulting in /k/ at the end of the first word. It should be obvious that this reference to orthographic information in no way undermines, or is incompatible with, the prosodic arguments put forth by McCarthy and Prince ((1986) et seq.) regarding clippings. In the same way, the fact that reference to orthography is illuminating for the analysis of ZG does not diminish its phonological interest since the intricate prosodic generalizations regarding ZG outlined above remain fully valid and demand an explanation, which can only be a prosodic one, as the remainder of the paper will amply demonstrate.¹⁰

Instead of denying the ZG argot's connection with the kana orthography and attempting to fully phonologize it, we suggest that the argot indeed be thought of as operating on the sequence of kana units (i.e., equivalent to moras and their associated melodies) but with the prosodic structure fully built on them, as in (11).

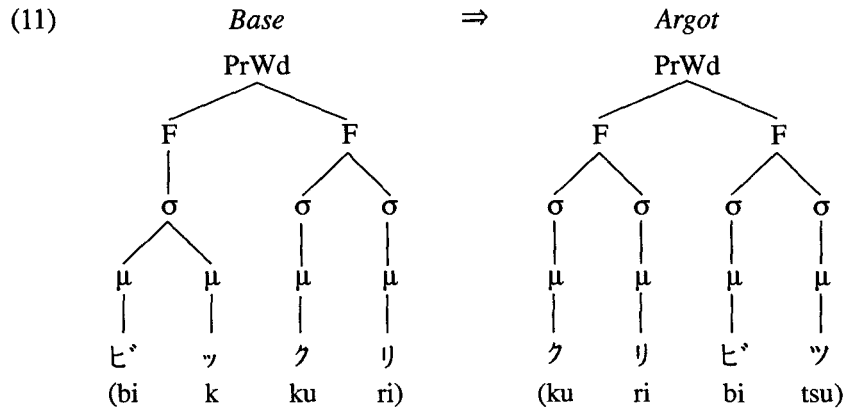

Adopting this kind of representation allows not only for a simple analysis of the forms with geminated consonants (and, as we will see later, of certain cases involving long vowels) but also for a proper treatment of the prosodic characteristics of ZG. For typographical convenience, we henceforth include the kana representation only when it diverges significantly from standard romanization, but it should be kept in mind that we assume that ZG always has kana-sized units at its disposal.¹¹ Our presentation of the relevant data in the following subsections proceeds in a stepwise fashion, from smallest inputs to successively larger ones, making generalizations along the way regarding the input-output (base-argot) relations.

2.1. 1μ - and 2μ -inputs

For short bases measuring only one or two moras, the argot form uniformly takes the trimoraic F+L structure:

(12) *Base* *Argot*
 $1\mu, 2\mu \longrightarrow 3\mu: F+L$

The examples in (13)–(15) show that all possible types of 1μ - and 2μ -sized bases (L, H, LL) result in H+L argot forms.¹²

(13) 1μ (L)

Base: L	hi	he	me	ka	su
Argot: HL	i: hi	e: he	e: me	a: ka	u: su

'cigarette light (lit.: fire)', 'fart', 'eye', 'mosquito', 'nest'

(14) 2μ (H)

Base: H	tsu:	ki:	no:	ai	paN
Argot: HL	u: tsu	i: ki	o: no	i: a	N: pa

‘expert’, ‘key’, ‘Noh play’, ‘love’, ‘bread’

(15) 2μ (LL)

Base: LL	meshi	hara	kyaku	jazu	imi
Argot: HL	shi: me	ra: ha	ku: kya	zu: ja	mi: i

‘meal’, ‘stomach’, ‘audience’, ‘jazz’, ‘meaning’

It is worth noting that the ZG-counterparts of CVN-bases such as *paN* in (14) are segmentally quite awkward. Japanese phonotactics restricts moraic nasals to the post-nuclear position of a syllable.¹³ In *N:pa*, however, the moraic nasal [N] not only occupies the nuclear position, but fills two moras and thus constitutes a foot by itself.

2.2. 3μ-inputs

Trimoraic base forms always give rise to trimoraic argot forms ((16)):

(16) *Base Argot*
 3μ → 3μ: F+L

In terms of the mapping relations between the parts of the base and the corresponding parts of the argot form, these reversals fall into two distinct subtypes:

- (17) (i) *Exhaustive reversals* The last two moras change places with the first mora.
 [1][23] → [23][1]
- (ii) *Nonexhaustive reversals* The first and third mora change places, leaving the second mora in situ: [1]2[3] → [3]2[1]. (The result is equivalent to reading the kana string backwards.)

With bases consisting of three light syllables (LLL), both the exhaustive ((18)) and the nonexhaustive type of reversal ((19)) are attested. (The type associated with a particular base depends on factors to be discussed later.)

(18) Exhaustive reversal

Base: LLL [1][23]	pi ya no	ku su ri	shi ka ke	o ka ma	ko do mo
Argot: LLL [23][1]	ya no pi	su ri ku	ka ke shi	ka ma o	do mo ko

'piano', 'drug', 'instigation', 'homosexual male', 'child'

(19) Nonexhaustive reversal

Base: LLL [1]2[3]	te ni su	sa ka na	ka ra da	ko ko ro	ta ta mi
Argot: LLL [3]2[1]	su ni te	na ka sa	da ra ka	ro ko ko	mi ta ta

'tennis', 'fish', 'body', 'heart', 'tatami mat'

For trimoraic bases with a heavy syllable (i.e., L+H and H+L), the reversal type is determined by the position of the heavy syllable: L+H bases undergo exhaustive reversal (20), whereas H+L bases choose nonexhaustive reversal ((21)).¹⁴

(20) Exhaustive reversal

Base: L H [1][23]	ni oi	fu meN	ya sui	ka no:	mo daN
Argot: H L [23][1]	oi ni	meN fu	sui ya	no: ka	daN mo

'smell', 'score', 'cheap', 'possible', 'modern'

(21) Nonexhaustive reversal¹⁵

Base: H L [1]2[3]	paN tsu	baN do	tai pu	doi tsu	be: su
Argot: H L [3]2[1]	tsuN pa	doN ba	pui ta	tsui do	su: be

'panties/briefs', 'band', 'type', 'German', 'bass'

In (21), the medical mora of the input – be it a moraic nasal, the second vowel of a diphthong, or a vowel length element – remains medial in the reversal, thus making the first syllable of the output heavy. Note that the last case, *su:be* (< *be:su* 'bass') is also classified here as a nonexhaustive reversal (and not as an exhaustive reversal combining a shortened /e:/ with a lengthened /u/). Given the extent to which the ZG argot reflects properties of the (moraic) kana systems (see the discussion in the introduction

and below), the nonexhaustive reversal interpretation is arguably the most natural one. The katakana script expresses vowel length by means of the special kana “-” (adding one mora to the preceding vowel). In katakana representation (22), the *be:su* \Rightarrow_{ZG} *su:be* reversal is nonexhaustive and entirely parallel to the other examples in (21).¹⁶

$$(22) \quad [1] \ 2 \ [3] \qquad [3] \ 2 \ [1]$$

$$\quad \text{へ}^\circ \text{ - } \text{ス} \quad \rightarrow \quad \text{ス} \text{ - } \text{へ}^\circ$$

$$\quad \text{be} \ : \ \text{su} \qquad \text{su} \ : \ \text{be}$$

The class of HL-bases also includes examples where the initial H is closed by a geminate obstruent ((23)):

(23) Nonexhaustive reversal

Base: H L [1]2[3]	kappa	tekka	rappa	wappa	yakko	batto
Argot: H L [3]2[1]	pakka	katte	patsura	patsuwa	kotsuya	totsuba

‘kappa (river imp)’, ‘tekka (roll)’, ‘trumpet’, ‘brat’, ‘guy’, ‘bat’

As discussed in the introduction (see (10) and (11)), the kana script indicates consonant gemination by a small /ʷ/ [tsu] preceding the kana whose onset consonant is geminated. In katakana representation ((24)), nonexhaustive reversal transfers the property of being geminated from the *p* to the *k* of *kappa* (*kap.pa* \Rightarrow *pak.ka*).

$$(24) \quad [1] \ 2 \ [3] \qquad [3] \ 2 \ [1]$$

$$\quad \text{カ} \ \text{ッ} \ \text{パ}^\circ \quad \Rightarrow_{ZG} \quad \text{パ}^\circ \ \text{ッ} \ \text{カ}$$

$$\quad \text{ka} \ \text{p} \ \text{pa} \qquad \text{pa} \ \text{k} \ \text{ka}$$

The examples of *rappa* \Rightarrow_{ZG} *patsura* and *batto* \Rightarrow_{ZG} *totsuba* are similar, with the added twist that the gemination kana /ʷ/ is pronounced as the full kana /ʷ/ [tsu]. Earlier, we witnessed this kind of “emergence of the full kana” when /ʷ/ was brought into word-final position through ZG reversal (see (10) in section 1). Here, segmentalization of /ʷ/ ((25)) is due to the dispreferred status of geminate rhotics, glides, and voiced obstruents in Japanese (**parra*, **pawwa*, **koyya*, **?tobba*).

$$(25) \quad [1] \ 2 \ [3] \qquad [3] \ 2 \ [1]$$

$$\quad \text{ラ} \ \text{ッ} \ \text{パ}^\circ \quad \Rightarrow_{ZG} \quad \text{パ}^\circ \ \text{ツ} \ \text{ラ}$$

$$\quad \text{ra} \ \text{p} \ \text{pa} \qquad \text{pa} \ \text{tsu} \ \text{ra}$$

In (22), (24), and (25), a switch of the first and the third kana-mora accounts for all aspects of the output including the fate of the medial

mora, without additional modifications. The contribution of the writing system here is entirely systematic and not of a sporadic nature.¹⁷

The diagram in (26) summarizes the situation found with the various types of 3μ inputs seen in this section.

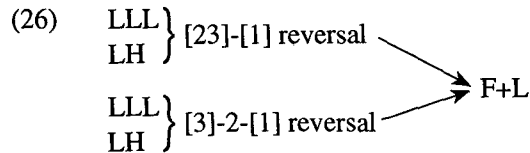

2.3. 4μ-inputs

There are five combinatorial possibilities of building a 4μ-word out of monomoraic and bimoraic syllables, as shown in (27).

(27)

a. LLL	b. HLL	c. HH
	d. LLH	
	e. LHL	

Under biomoraic trochaic footing, these sequences are internally structured as in (28).

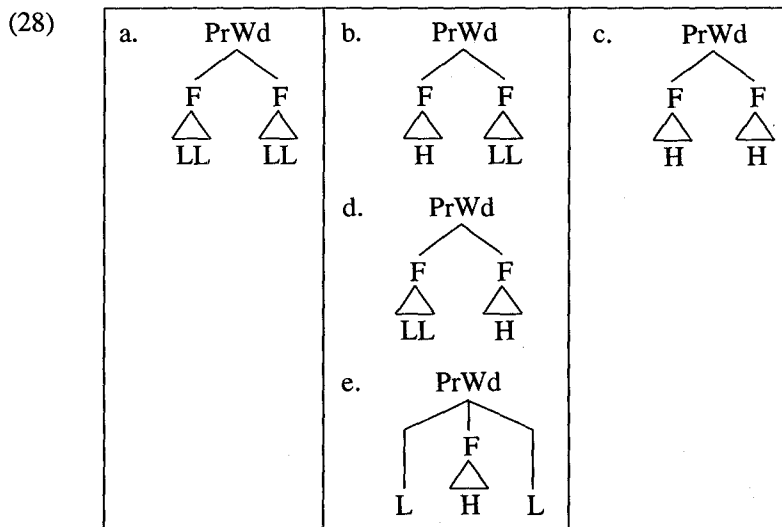

The first four of these structures (28a-d) are binary, each consisting of two feet. Their argot counterparts have the same shape, with the two feet reversed (29). Things are less straightforward with the fifth structure (28e),

the ternary LHL, where we find two different outcomes, depending on the base: either F+F, or the null output.

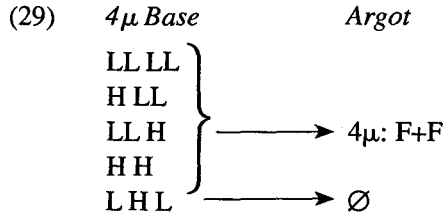

Examples of the first group, where both base and argot have the form F+F, appear in (30)–(33).¹⁸

(30)

Base: LL+LL	sopurano	ikebana	karaoke	kasutera	yamagiwa
Argot: LL+LL	ranosopu	banaike	okekara	terakasu	giwayama

‘soprano’, ‘flower arranging’, ‘karaoke’, ‘cake’, ‘Yamagiwa’

(31)

Base: LL+H	takushi:	batsugun	sukebe:	kichigai	pasokon
Argot: H+LL	shi:taku	gunbatsu	be:suke	gaikichi	konpaso

‘taxi’, ‘fabulous’, ‘lecher’, ‘crazy’, ‘personal computer’

(32)

Base: H+LL	henteko	o: hira	dai suke	bat chiri	ip patsu
Argot: LL+ $\left\{ \begin{matrix} H \\ LL \end{matrix} \right\}$	tekohen	hira o:	suke dai	chiri batsu	patsu ichi

‘weird’, ‘Ohira’, ‘Daisuke’, ‘thoroughly’, ‘one shot’

(33)

Base: H+ H	ko: hi:	ku: ra:	ka: chan	op pai	gak ko:
Argot: H+ $\left\{ \begin{matrix} H \\ LL \end{matrix} \right\}$	hi: ko:	ra: ku:	chan ka:	pai otsu	ko: gaku

‘coffee’, ‘air conditioner’, ‘mother’, ‘breast’, ‘school’

Some of the bases in (32) and (33) begin with a geminate-closed syllable. As discussed in the introduction (see (9) and (10)), their argot forms have an extra syllable for phonotactic reasons (since obstruent-closed syllables cannot occur word-finally). What is initially surprising about (32) and (33) is the variety of “epenthetic” syllables encountered: Besides the familiar

[tsu], we also find [chi] and [ku], depending on the example. The source of these extra segments is no mystery for any reader who has some basic familiarity with Japanese: they come from the readings of the characters constituting the kanji representations of these words (*ip patsu* →_{ZG} *patsu ichi*,¹⁹ *gak ko:* →_{ZG} *ko:gaku*, etc.), providing further evidence for the relevance of graphemic factors.

LHL forms are unique among 4μ-words in that they have no binary analysis into feet. As the first three examples in (34) show, the argot counterparts for such words have the same total number of moras but grouped in a different way – as a smooth F+F sequence, achieved through a combination of lengthening and shortening.²⁰

(34)

Base: LHL	suto:bu	depa:to	shiro:to	sekando	furaito
Argot: { H+LL Ø }	bu:suto	to:depa	to: shiro	Ø	Ø
				??itofura	

‘stove’, ‘department store’, ‘amateur’, ‘second’, ‘flight’

The last two examples in (34) demonstrate that ZG mapping fails for some types of LHL inputs, namely, for all those whose medial heavy syllable has a segmentally complex rhyme. As will be seen in section 4 below, this gap is due to the fact that a compression of such heavy syllables to monomoraic size would entail fatal segmental losses over and above the moraic shortening.

In sum, 4μ words present a simpler picture than 3μ words. Their ZG correspondents measure 4μ, structured as F+F, with crosswise correspondence between the two halves of each form. The nonbinary input type LHL maps onto F+F outputs whenever H = cv:, otherwise there is no ZG output.

2.4. 5μ⁺-inputs

Most bases measuring five moras or more (henceforth, 5μ⁺-forms) do not have a corresponding ZG form (35b). In those cases where an argot form exists, it is made to fit the F+F frame by shortening (35a).

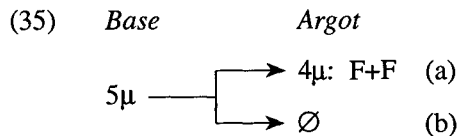

There are eight combinatorial possibilities of building a 5μ-word out of monomoraic and bimoraic syllables, as shown in (36).

(36)

LLLLL	HLLL	HHL
	✓ LHLL	HLH
	LLHL	✓ LHH
	LLLH	

The ZG-behavior of these 5μ-bases is determined by their internal grouping structure. An acceptable ZG-output of the form F+F exists only for the two types highlighted in (36), which have an initial LH sequence followed by F (LL or H), structured as in (37). Some examples of this type appear in (38).

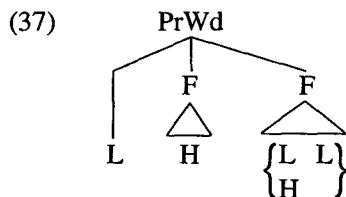

(38)

Base: LH {LL H}	koma:sharu	reko:da:	mane:ja:	jido:kan	karenda:
Argot: {F+F Ø}	sharu koma	da: reko	ja: mane	kan jido	Ø

‘commercial’, ‘recorder’, ‘manager’, ‘children’s hall’, ‘calendar’

In (38), the first F in the Argot form (*sharu, da:*, etc.) corresponds exactly to the final LL/H in the base, and the second F in the Argot form (*koma, reko,* etc.) corresponds to the first two syllables in the Base (*koma:, reko:*, etc.) by “iambic shortening” (LH → LL, see Kager (1993), Mester (1994) among others), i.e., with loss of one mora in the second syllable. Similar to the findings in the case of 4μ-words in section 2.3 (see (34)); this kind of shortening is possible only when H contains a long vowel and is therefore compressible without segmental loss. Whenever H has a complex rhyme, such as the last example in (38) *karenda:*, there is no Argot form (shortening would lead to the loss of a melodic element (**da:kare(N)*)).

Returning to the list of 5μ input structures in (36), none of the other types yield acceptable argot forms, as shown in (39) for some illustrative examples.

(39)

Base	LLLL kurisumasu	HLLL taipisuto	LLHL arubaito	LLLH akademi:	HHL kantso:ne	HLH ku:deta:
Argot	∅	∅	∅	∅	∅	∅

'Christmas', 'typist', 'part-time work', 'academy', 'canzone', 'coup d'état'

For inputs measuring 6μ or more, there are also no fully acceptable argot forms (40), as shown in (41) with some illustrative examples.²¹

(40) *Base* *Argot*
 $6\mu^+ \longrightarrow \emptyset$

(41)

Base: 6μ	o:kesutora	kontoro:ru	kurasume:to	jaNkenPON	su:pa:maN
Argot: ∅	∅	∅	∅	∅	∅

'orchestra', 'control', 'classmate', 'paper-scissors-stone', 'superman'

It should be noted here that the lack of an acceptable argot form for the $6\mu^+$ examples in (39) and (41) is not exclusively due to the melody loss factor.²² In many cases, argot forms are conceivable which involve no segmental melody loss (e.g., *su:pa: maN*, **maNsupa*) but are nevertheless disallowed. In previous studies of ZG, such as Tateishi (1989) and IKM (1992), there was a tendency to emphasize the free availability of shortening and lengthening to make the output fit the "template," taking the absence of a large number of expected outputs as accidental. However, a more systematic survey shows quite unambiguously that both augmentation and compression of moraic structure are in fact restricted to a very limited range of environments. In particular, input forms measuring 5μ or more produce output argot forms only for the "iambic shortening" case seen in (38).

2.5. Superheavy Syllables

Trimoraic syllables, disfavored universally and shown to be unstable in Japanese (see Poser (1990) and Kubozono (1991) for discussion), occur primarily in recent loans. Just as heavy syllables, superheavy syllables project their own foot (a dispreferred trimoraic structure notated below as F').

(42)

Base: ... + F'	to:N	sa iN	pa ta:N	toroNbo:N
Argot: F + ...	N: to	iN sa	N: pata ²³	boN toro

'tone', 'sign', 'pattern', 'trombone'

The argot form for the monosyllabic *to:N* follows the pattern of bimoraic monosyllables like *paN* (14) discussed in section 2.1. For [*saiN*], the split occurs within the diphthong, avoiding a nasal nucleus.²⁴ The base-argot pair (*toroNbo:N*, *boNtoro*) is exceptional in two ways: First, the trimoraic syllable is compressed to bimoraic size in the argot form (this also holds true of the alternant ZG form for *pata:N* cited in note 23); and secondly, one of the moraic nasal melodies is lost. One might appeal to a kind of OCP-“fusion” where the single *N* in the argot corresponds to both *N*'s in the base. However, this is an isolated and lexicalized example, and any such proposal will necessarily remain speculative since neither trimoraic foot compression nor melody loss appear to be productive strategies, according to our survey.

For the analysis, it is important to separate such sporadic phenomena from those that occur with regularity: here, nasal nucleus formation and diphthong splitting. And finally, behind all the peculiarities and indeterminacies surrounding the ZG-treatment of superheavy syllables, note that the argot's prosodic shape is strictly observed even here: Only F+F and F+L are found as ZG forms.

2.6. Synopsis

Assembling all the individual input-output relations documented in the preceding subsections yields the overall pattern in (43). An important task of the analysis to be presented in the remainder of this paper will be to show why ZG-mapping is organized in this particular way.

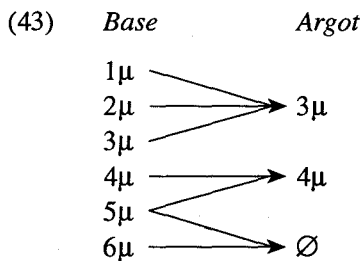

3. TEMPLATIC EFFECTS

Recent work in Prosodic Morphology has resulted in an improved understanding of the role and nature of prosodic *templates* – prosodic shape requirements imposed on certain morphological categories and formations, typically expressed by single categories such as “σ” (syllable) or “F” (foot) but also by combinations of such categories, such as the “F+F” and “F+L” templates characteristic of the ZG-argot (see the survey in section 2). Rather than as a construction-specific stipulation of some particular target category encapsulating all the relevant information, a template is properly treated as an assertion of (particular aspects of) prosodic unmarkedness over a certain domain. The first explicit statement to this effect appears in Steriade (1988), where attention is drawn to reduplication requirements found in a number of languages preventing the reduplicant from having a coda, a complex onset, etc., as the case may be. Simply extending the list of genuine prosodic categories by dubious new members like the core (cv) syllable, etc., does little to advance our understanding of such phenomena. The crucial step is to recognize that they are nothing but syllable markedness effects: preferred syllables are open, have simple onsets, etc. It is thus the unmarked state of affairs that asserts itself in the form of specific requirements in reduplication and other prosodic-morphological formations. A further step in this direction was the proposal (McCarthy and Prince (1990) et seq.) to identify the minimal prosodic word with the unmarked prosodic word, thus replacing the minimization operator of earlier work (McCarthy and Prince (1986)).

The intrinsic limitation, both at an explanatory level and from a descriptive point of view, of the concrete prosodist’s identification of templates with specific prosodic target categories becomes obvious once some sufficiently rich and well-documented templatic system is analyzed in some depth. Thus a comprehensive study of the different prosodic shapes encountered among truncations in modern Japanese (Itô and Mester (1992)) revealed that no single prosodic category, or concatenation of categories, is sufficient to capture the observed limitations in an adequate way (truncated forms in Japanese are not necessarily “minimal” in any obvious sense, etc.; see also Archangeli (1991) for an analysis of a similar templatic system in Yawelmani Yokuts). The basic requirement is rather (Itô and Mester (1992, 16–17)) that truncated forms must be “wellformed *prosodic words*, nothing more and nothing less [. . .]” – a trivial demand by itself, which nevertheless – when combined with an aggressive assertion of principles defining prosodic unmarkedness – results in an extremely limited pool of permitted prosodic forms at the observational level.

3.1. *Prosodic Form: Approaching the Ideal*

It is this more indirect and more abstract view of templates, which aims at a deeper explanation and is at the same time analytically more flexible (since markedness principles of various kinds can be invoked), that has since developed in important ways within Optimality Theory. Here, templatic requirements on outputs result from a constraint interaction pattern often referred to as the “emergence of the unmarked” (McCarthy and Prince (1994, 1995)). In this conception, various instantiations of faithfulness, while not identified with each other, are still unified in terms of Correspondence Theory. “Lexical-Surface Faithfulness” refers collectively to the set of faithfulness requirements operative in the “normal” (surface) phonological parsing of underlying (lexical) input forms by optimality-theoretic grammar (cf. the Parse and Fill constraints in standard OT). Related but distinct from these are constraints governing correspondence in other types of formations, in particular, in reduplication (McCarthy and Prince (1994, 1995), Urbanczyk (1995)), prosodic circumscription (McCarthy (1995)), truncation (Benua (1995)) and, for the case under discussion here, Base-Argot correspondence holding in ZG (44).²⁵

(44) ZG Correspondence Model:²⁶

Lexical /koma:sharu/	
↓	
Surface [ko(ma:)(sharu)]	→ [(sharu)(koma)]
Base	Argot

‘commercial’

The central idea is that unmarked prosodic form asserts itself because the faithfulness requirements holding for a particular type of grammatical relationship – here, Base-Argot (BA) – are subordinated to the relevant prosodic constraints, in contrast to Lexical-Surface (LS) faithfulness. This crucial scenario is schematically indicated in (45).

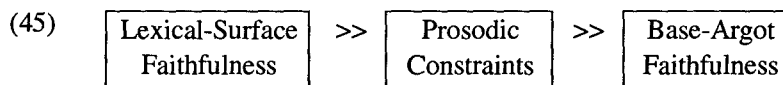

The general conception of faithfulness developed in McCarthy and Prince (1995) and McCarthy (1995) centers around the constraints Max and Dep, as defined below (slightly reformulated for our purposes; see sections 4 and 5 for a more rigorous formal development and discussion). Max (*I-to-O correspondence*) evaluates whether every input element corresponds

to an output element, and Dep (*O-to-I correspondence*) evaluates whether every output element corresponds to an input element.

(46) Let I, O be linguistic representations connected by some linguistic process as input and output; let $a \in I$, $b \in O$ (elements), and let \mathcal{R} be a correspondence relation on I, O.

a. **Max:** \mathcal{R} is total with respect to I: Every element of I has a correspondent in O.

$$\forall a \exists b [a\mathcal{R}b] \quad (\text{"Domain } (\mathcal{R}) = I\text{"})$$

b. **Dep:** \mathcal{R} is total with respect to O: Every element of O has a correspondent in I.

$$\forall b \exists a [a\mathcal{R}b] \quad (\text{"Range } (\mathcal{R}) = O\text{"})$$

Max and Dep each belong to a larger family of related constraints (dealing with I-to-O and O-to-I correspondence, respectively). Other members of the Max- and Dep-families of constraints will appear below (e.g., the Max- μ constraint in (47) requires every input mora to have an output correspondent, etc.).²⁷

The two partial tableaux in (47)–(48) illustrate the overall scenario of (45). The phrase “Prosodic Form Constraints” is an informal stand-in for those constraints which, when fulfilled, lead to the two optimal prosodic forms F+F and F+L (we return to the exact nature of these constraints below in section 3.2).

(47) Lexical-Surface Correspondence

Lexical	Surface	LS Moraic Faithfulness	“Prosodic Form Constraints” (resulting in F+F or F+L)
/koma:sharu/	a. ko(ma:)(sharu)		*
	b. $(koma)(sharu)$	*! (Max- μ)	

‘commercial’

LS-Faithfulness outranks the prosodic constraints – in cases of conflict, as in (47), the imperative to remain faithful to the underlying form weighs more than the imperative to assume an unmarked prosodic shape.²⁸ Thus (47a) with an undesirable LFF structure wins over the moraicly unfaithful (47b) (violating Max- μ).

While outranked by LS-Faithfulness, the prosodic form constraints themselves outrank BA-Faithfulness, the constraints demanding argot forms to be faithful to their bases (48).²⁹

(48) Base-Argot Correspondence

Base	Argot	"Prosodic Form Constraints" (resulting in F+F or F+L)	BA Moraic Faithfulness
ko(ma:)(sharu)	a. (sharu)ko(ma:)	*!	
	b. [☞] (sharu)(koma)		* (Max-μ)

This means that conflict resolution proceeds here in the opposite way. The winning candidate (48b) violates Max-μ but is prosodically optimal. Base-Argot Faithfulness is violated in order to remodel the prosodic shape of the form so as to fulfill the prosodic constraints – in other words, the prosodic constraints collaborate to impose a “template” of F+F or F+L on output forms at the cost of distorting the base form over and above the reversal (the reversal aspect will be taken up in section 4).

The tableaux (49)–(50) show a parallel example involving a member of the Dep-family of constraints, namely, Dep-μ (militating against output moras without input correspondents).

(49) LS Correspondence

LexRep	SurfaceRep	LS Moraic Faithfulness	"Prosodic Form Constraints" (resulting in F+F or F+L)
/meshi/	a. [☞] (meshi)		*
	b. (me:) shi	*! (Dep μ)	
	c. (me:) (shi:)	*!* (Dep μ)	

‘food’

(50) BA Correspondence

Base	Argot	"Prosodic Form Constraints" (resulting in F+F or F+L)	BA Moraic Faithfulness
(meshi)	a. [☞] (shi:)me		* (Dep μ)
	b. (shi:)(me:) ³⁰		**! (Dep μ)
	c. (shime)	*!	

‘food’

The splitting and separate ranking of the two types of faithfulness here and in many other similar cases (McCarthy and Prince (1994, 1995)) encodes the limitation of markedness conditions to prosodically derived categories stipulated in earlier work (see Itô (1990, 223–227) on minimality for “derived” items, and Itô and Mester (1992, 21–22) on binary branching as holding only for “p[rosodically]-derived words”). While it is to be

hoped that future work will lead to a more principled explanation in this area, the strength of the Max/Dep approach is that it unifies the various faithfulnesses through a shared correspondence-theoretic language. With its multiple sets of faithfulness requirements, one for each correspondence in the grammar (lexical-surface, base-reduplicant, base-truncatum, base-argot, etc.), the correspondence model is reminiscent of the core-periphery model of the grammar developed in Itô and Mester (1995b), where lexicon-internal variation, as manifested by the existence of different lexical strata, is reduced to variant ranking of faithfulness constraints with respect to the (invariant) rest of the constraint system.

In (51), the overall constraint ranking is shown as projected from our ZG correspondence model. The visual depiction is intended to indicate that different sets of faithfulness constraints for LS and BA should not be considered independent and unrelated but as different projections of the same pool of operative faithfulness constraints, which are projected higher than the prosodic form constraints in the LS dimension but lower in the BA dimension. Perhaps future research will uncover the principled reasons for why the ranking is different in different dimensions, leading to a more unified model.³¹

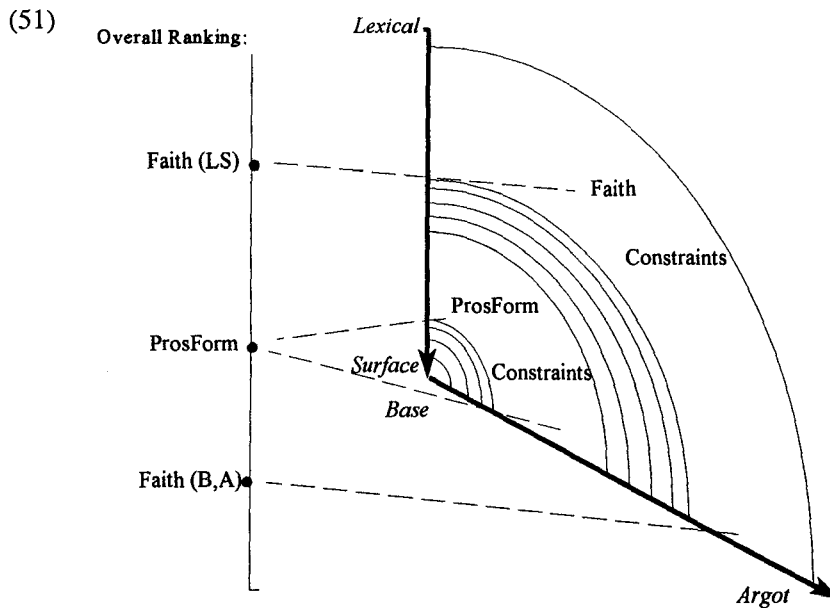

3.2. Hierarchical Alignment and NonFinality

Given this basic scheme resulting in the exclusive appearance of unmarked prosodic shapes in formations like the ZG argot, a crucial task of the analysis is to determine the nature of the prosodic constraints that define prosodic unmarkedness in the intended sense. What is unmarked about the patterns F+F and F+L? Descriptively, these formations are strictly binary at the level of the prosodic word, with no more, and no less, than binary branching. Thus, [FF] and [FL] are admitted, but neither ternary structures like [FFF] or [LFL], nor the unary structure [F], are admitted. There are a number of options for deriving the unmarkedness of such strictly binary prosodic structure within Optimality Theory. We could choose the direct route, following IKM (1992) and Itô and Mester (1992) (and others, in different contexts), and enshrine strict binarity as a desideratum of all prosodic (or: linguistic) structure, by means of a specific constraint to that effect. While this line of attack is not without merit, its directness has a price: No further phonological explication of the unmarkedness of strictly binary structure is deemed possible, or necessary. A detailed exploration of the issues would take us too far afield in the present context (see Itô and Mester (1995c) for further details and motivation); as a matter of execution we will here follow the work cited in assuming that strictly binary structure can be obtained as a consequence from more elementary principles, namely, Hierarchical Alignment (effectively disfavoring a degree of branching higher than binary, see below) and NonFinality (banning the head foot from PrWd-final position; see Prince and Smolensky (1993)).

The intuitive idea of Hierarchical Alignment (Itô and Mester (1995c)) is the following: In prosodic structures with no more than binary branching, every constituent lies at an edge (left or right) of some larger constituent, i.e., is *prominent* within some larger constituent. Constituent prominence in (maximally) binary structures can be expressed as alignment within a higher constituent, as illustrated in (52).

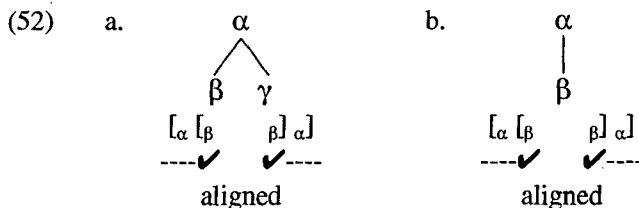

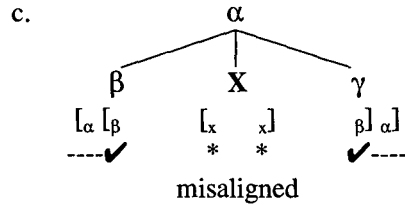

In the binary structure (52a), β is L-aligned with α , and γ is R-aligned with α . In the unary structure (52b), β is both L- and R-aligned with α . In the ternary structure (52c), X is neither L- nor R-aligned with α . A formal definition of Hierarchical Alignment follows in (53).

- (53) **Hierarchical Alignment:** Every prosodic constituent is aligned with some prosodic constituent, containing it.

$$\forall \text{PCat1} \exists \text{PCat2} [\text{PCat2} \supset \text{PCat1} \ \& \ \text{Align} (\text{PCat1}, \text{PCat2})]$$

(53) is an alignment scheme that can be unfolded into individual constraints for various instances of PCat1.³² “PCat” stands for “string that is a PCat,” “constituent of type PCat,” and PCat1 cannot be the root of a prosodic tree (which is intrinsically prominent anyway since it is not embedded in a larger constituent). Since Hierarchical Alignment requires a containment (domination) relation between the two categories in question, same-edge matching (L/L or R/R) need not be separately stipulated (constituents aligned at opposite edges can obviously never stand in a containment relation). The basic effects of Hierarchical Alignment at the foot- and at the word-level are illustrated in (54).

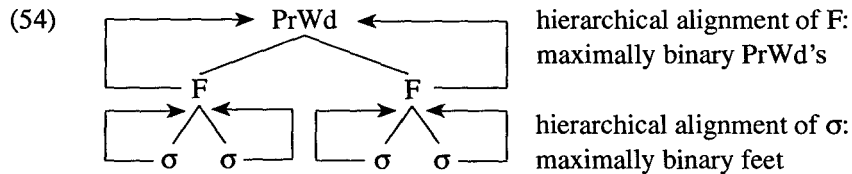

Ternary PrWd's violate Hierarchical Alignment at the Foot level (55a), ternary feet at the σ level (55b)

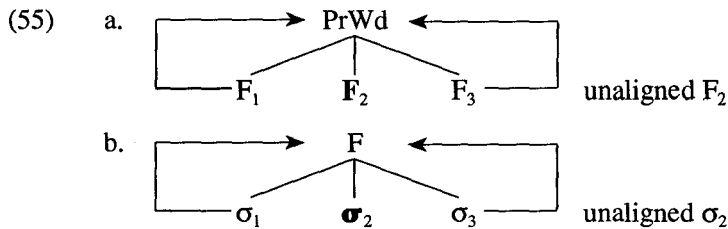

Weakly layered ternary structures like (56) fare equally badly in terms of hierarchical alignment.

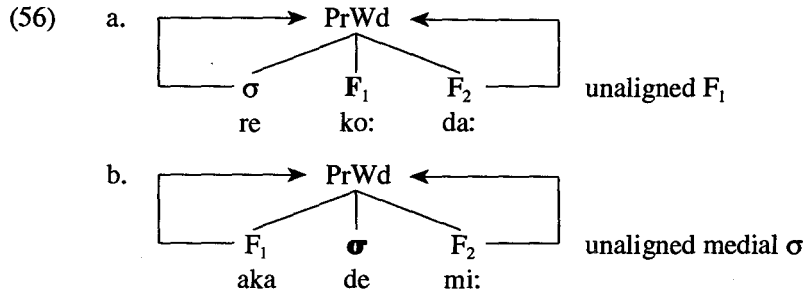

Binary branching as an upper limit is thus a consequence of a constraint demanding hierarchical alignment (and perhaps ultimately: prominence within some domain) of every prosodic constituent. Since this prosodic constraint ranks below LS-Faithfulness, many Japanese words (such as those in (56)) have ternary structure. On the other hand, Hierarchical Alignment dominates BA-Faithfulness, with the consequence that F+F and F+L (57) are the only output shapes attested in the ZG-Argot, often at the price of significant BA-Faithfulness violations.



Binary structure as a lower limit of PrWd-structure means that a single foot, as in (58), is not admitted. As suggested in Itô and Mester (1995c), this is best understood as a consequence of Nonfinality(F'), in the sense that the head foot (F') of the prosodic word must not stand in final position (see also the analysis in Suzuki (1995), which independently arrives at a similar conclusion).³³

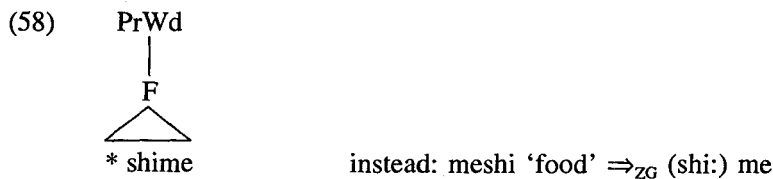

Just as FL structures, FF structures – which we take to be head-initial: F'F – do not violate Nonfinality(F'). The NonFinality approach has the advantage that it subsumes the exclusion of the nonbranching [F]_{PrWd} (58) and of the loose-syllable-initial [ǝF]_{PrWd} (59) under the same generalization:

Both structures violate Nonfinality because of the position of their only (and therefore head-) foot.³⁴

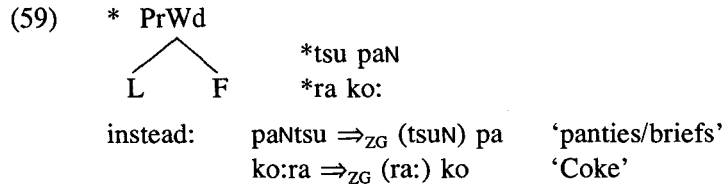

(60) shows the individual Prosodic Form Constraints, ranked above the BA Faithfulness constraints:

(60)

Candidate Pairings:		Prosodic Form Constraints		BA Faithfulness	
Base	Argot	HierAlign	NonFin(F')	Max- μ	Dep- μ
ko(ma:)(sharu)	a. (sharu)ko(ma:)	*!			
	b. [F] (sharu)(koma)			*	
(meshi)	c. (shime)		*!		
	d. [F] (shi:)me				*
(paN)tsu	e. tsu (paN)		*!		
	f. [F] (tsuN) pa				
	g. (tsu:)(paN)				*

'commercial', 'food', 'panties/briefs'

The moraically faithful candidates in these three tableaux show fatal prosodic form violations: they are either hierarchically misaligned (60a) or (head-)foot final (60c,e). NonFinality(F') is not violated in (60a,b), (60d), and (60f,g) because the word-final foot is not the head foot. In the last case, both (60f) and (60g) fulfill the prosodic form constraints, and the crucial decision is handed down to the faithfulness constraint (Dep- μ) (see section 5 for further discussion of similar cases).

4. REVERSAL AS CROSS-ANCHORING

As developed up to this point, our analysis of ZG shows that, as far as a derived form's commitment to its source is concerned, the central difference between the argot and ordinary Japanese lies not in the faithfulness constraints themselves but rather in their ranking with respect to other constraints.³⁵ Thus the different impact of the two versions of Max- μ seen in the last section, Max- μ (LS) and Max- μ (BA), is due not to any intrinsic difference but rather to their ranking with respect to the prosodic form constraints Hierarchical Alignment and NonFinality(F').

We now direct our attention to one type of constraint whose BA-version diverges drastically from its LS-version. The constraint in question, which accounts for the obligatory reversal found in ZG forms, is responsible for the fact that argot formation in some respects steps beyond the formal options otherwise encountered in the phonologies of natural languages – not in some arbitrary way, but rather by extending the parameters of a certain grammatical constraint beyond its natural-language limitations. The constraint family in question is known as Anchoring (McCarthy and Prince (1995)). In general, a representation X counts as successfully anchored to another representation Y if their edges match: Left edge corresponds to left edge, right edge to right edge (i.e., the two are occupied by corresponding elements). The lexical representation /karaoke/ and the surface phonological representation (*kara*)(*oke*) trivially fulfill left- and right-anchoring in this way. But in ZG, the orientation of edge-material has been switched around (61): The beginning of the argot form (here, *oke*) corresponds to the end of the base, and the end of the argot form (here, *kara*) corresponds to the beginning of the base form.

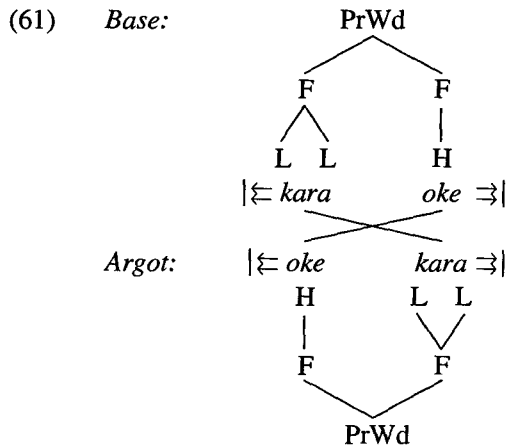

In this section, we formulate an optimality-theoretic constraint of Cross-Anchoring (76) which, parasitically added to the normal phonological grammar in an undominated position, results in ZG-reversed forms as in (61). While the formal statement of Cross-Anchoring deviates only minimally from ordinary-language anchoring constraints, its effects are dramatically different, in ways permissible only in the broader arena of linguistic games and argots, not in linguistic grammar per se.³⁶ Similar constraints are arguably responsible for many other reversing language games (see Bagemihl (1989) for an extensive typology and formal analysis). The perhaps most remarkable result is that Cross-Anchoring, in spite of

the properties that set it apart as a constraint, still interacts with the rest of the system in normal optimality-theoretic ways – through strict domination and minimal violation.

4.1. *String-to-String Correspondence and Anchoring*

Given two phonological representations S_1 and S_2 linked by some linguistic derivation, Right-Anchor (S_1, S_2), as defined in McCarthy and Prince (1995, 317), ensures that if some element a is rightmost in S_1 and another element a' rightmost in S_2 , then a and a' are correspondents (and analogously for Left-Anchor). LS pairings such as /karaoke/ ~ (kara)(oke) provide a straightforward illustration. The anchoring between base and reduplicant is similar, with the difference that under conditions of partial reduplication one of the two, either L-Anchor or R-Anchor, must be violated.³⁷ Restating a proposal in Marantz (1982) within a contemporary framework, it is suggested that prefixing reduplication goes hand-in-hand with the ranking L-Anchor >> R-Anchor, and suffixing reduplication with the opposition ranking: Thus (hypothetical) *ka-karaoke* is L-Anchored but not R-Anchored, and *karaoke-ke* is R-Anchored but not L-Anchored.³⁸

Written out in a slightly redundant form for our purposes, L(exical)-S(urface)- and Red(uplicant)-Base-Anchoring can be expressed as in (62)(using the syntax of alignment statements proposed in McCarthy and Prince (1993b)).

- (62) a. Red-Base Anchoring
 Anchor (Red, Left, B, Left)
 Anchor (Red, Right, B, Right)
- b. L(exical)-S(urface) Anchoring
 Anchor (S, Left, L, Left)
 Anchor (S, Right, L, Right)

Cross-Anchoring, on the other hand, must be defined in such a way that in anchoring A(rgot) to B(ase), edges are reversed instead of preserved: Some element located at the left edge of the argot form corresponds to an element at the right edge of the associated base, and vice versa.³⁹ This is expressed in (63) in a schematic way.

- (63) Argot-Base Anchoring (preliminary formulation)
 Anchor (A, Right, B, Left)
 Anchor (A, Left, B, Right)

In order to fulfill (63), linear precedence relations are drastically altered between base and argot. In other words, massive violations of the constraint demanding the preservation of linear order under correspondence are legitimized under the pressure of the dominant Cross-Anchoring constraint. This is, in outline, our basic analysis of the ZG reversal phenomenon. In order to avoid distracting technicalia at this point, we mark linearity violations by listing, in a compact form, the substrings whose order has been switched. Tableau (64) illustrates the type of constraint interaction that is constitutive of the ZG-argot.

(64) Argot-Base Anchoring >> Linearity:

Base	Argot	Argot-Base Anchoring	Linearity
(kara)(oke)	a. \leftarrow (oke)(kara)		oke < kara
	b. (kara)(oke)	*!	

What remains to be settled about (63) is the nature of the objects whose edge-orientation is reversed. The intended answer is clear from the empirical generalizations laid out in section 2: Reversal does not affect single edge *segments* but rather edge *strings* (usually prosodic constituents, for independent reasons). In order to adequately express this within a correspondence-theoretic framework, we need to lift the notion “correspondence” from the level of elements to the level of strings, such that a string x can have a string y as its (string-)correspondent. To facilitate this, we introduce a few ancillary notions and notational conventions.⁴⁰ Letters from the beginning of the alphabet (a, b, c, d, \dots) denote segments, and letters from the end of the alphabet ($\dots w, x, y, z$) (as well as the mnemonic S) denote strings. Formally speaking, a string is neither simply a set of elements nor a sequence of elements but rather the result of applying an operation (namely, concatenation) to a set of elements, where set and operation form a specific algebraic structure, namely, a semigroup (see, e.g., Partee (1978, 22)). In order to have a simple way of referring to the members of a string S , we define the set of segments of S – $\text{segs}(S)$ – as in (65) (elements that occur more than once in S are taken to constitute distinct string segments, distinguished by position indices).

(65) Def. “segments of a string”
 $\text{segs}(S) =_{\text{def}} \{a \mid \exists x, y [S = xay]\}$

The relations “membership in a string” (“ \in_s ”) and “substring of a string” (“ \subseteq_s ”) are defined in (66).

(66) a. Def. “membership in a string”

$$a \in_s S =_{\text{def}} a \in \text{segs}(S)$$

b. Def. “substring of a string”

$$x \subseteq_s S =_{\text{def}} \exists wy [S = wxy]$$

Taking up the proposal in McCarthy and Prince (1995, 262) and restating it for our purposes, we define *correspondence* as in (67).

(67) Def. “Correspondence”

Given strings x and y , a *correspondence* \mathcal{R} is any relation between $\text{segs}(x)$ and $\text{segs}(y)$, i.e., any subset of the cartesian product of $\text{segs}(x)$ with $\text{segs}(y)$:

$$\mathcal{R} \subseteq \{\text{segs}(x) \times \text{segs}(y)\}$$

Given the strings $x = a_1a_2a_3a_4$ and $y = b_1b_2b_3b_4$ and their associated segment sets X and Y , the cartesian product $X \times Y$ is illustrated in (68). Note that any subset of the set of cells in this matrix constitutes a relation and hence a correspondence between x and y .

(68)

$X \times Y$	b_1	b_2	b_3	b_4
a_1	a_1b_1	a_1b_2	a_1b_3	a_1b_4
a_2	a_2b_1	a_2b_2	a_2b_3	a_2b_4
a_3	a_3b_1	a_3b_2	a_3b_3	a_3b_4
a_4	a_4b_1	a_4b_2	a_4b_3	a_4b_4

The diagonal relation $\{a_1b_1, a_2b_2, a_3b_3, a_4b_4\}$ is, in autosegmental parlance, a one-to-one, no-skipping, no-crossing relationship (69a), whereas the other diagonal $\{a_1b_4, a_2b_3, a_3b_2, a_4b_1\}$ yields a maximal crossing effect (69b) found in some language games (Bagemihl (1989)).

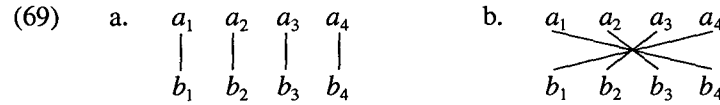

In (70), we extend the notion *correspondence* from the segment-level to the string-level.

(70) Def.: “String-correspondence”

x stands in string-correspondence \mathcal{R}_s with y iff there is a correspondence \mathcal{R} such that every segment of x has a correspondent in y , and every segment of y has a correspondent in x .

$$x\mathcal{R}_s y \equiv_{\text{def}} \forall a \in_s x [\exists b \in_s y (a\mathcal{R}b)] \wedge \forall c \in_s y [\exists d \in_s x (d\mathcal{R}c)]$$

The fact that all correspondence is grounded in phonological substance (as stressed by McCarthy (1995)) does not lend support to some version of segmentism claiming that only segments can be meaningfully said to stand in correspondence. Extending the notion of correspondence is particularly important for prosodic constituents, i.e., strings that make up particular prosodic categories. In order to clarify the relation between “string,” “prosodic category,” and “prosodic constituent,” compare (71a), the familiar kind of tree diagram for prosodic structures, with the equivalent mode of representation in (71b), which gives greater prominence to the *string* character of prosodic constituents. In our extensionalist conception of prosodic structure, prosodic categories themselves are nothing but sets of strings.⁴¹

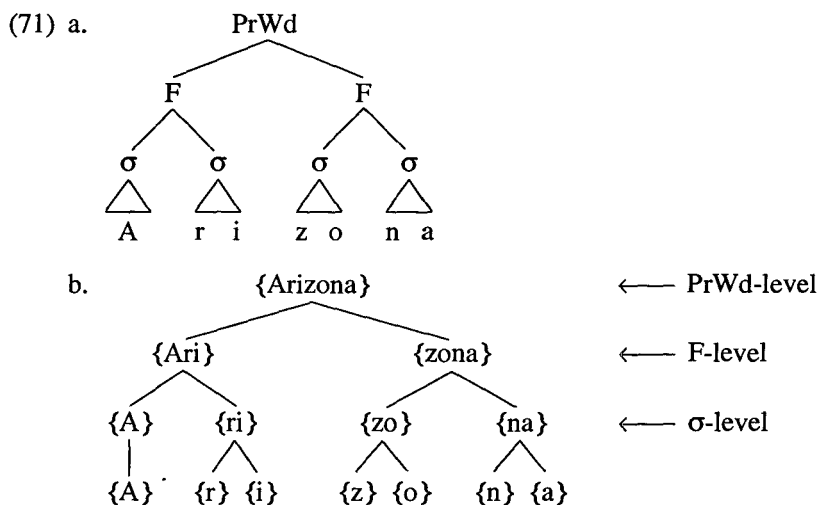

Having made the distinction between \mathcal{R} (“segment-correspondence”) and \mathcal{R}_s (“string correspondence”), we will usually refer to both as “correspondence,” reserving the more specific terms to occasions when the distinction is relevant.

Anchoring is concerned with edges; string-correspondence raises the issue as to what should count as the edge of a string. Serious work in theoretical phonology has long overcome the category error of reifying edges into some kind of boundary element that literally inhabits the phonological representation (for discussion, see Pyle (1972), Rotenberg (1978), as well as more recent literature). On the other hand, a segmentalist view insisting on the identification of edges with individual edge segments errs at the other extreme: While ontologically parsimonious, it is insufficiently general for more complex tasks of phonological analysis, such as the one

at hand here. On general conceptual grounds, it seems ill-advised to legislate in some general way where, for example, the “left edge” of a form should end: after the first segment? after the first syllable? after the first foot? etc. (see Spaelti (1994) for discussion and a proposal).

Taking up ordinary English usage, we say that a string x *begins/ends* a string S iff x is an initial/final substring of S , as expressed in (72a,b). Furthermore, the *beginnings* of S are the set of strings that *begin* S ((73a)), and the *endings* of S the set of strings that *end* S ((73b)).

- (72) a. x begins $S \equiv_{\text{def}} \exists y [S = xy]$
- b. x ends $S \equiv_{\text{def}} \exists y [S = yx]$

- (73) a. “beginnings of S ”: beginnings (S) $=_{\text{def}} \{x|x \text{ begins } S\}$
- b. “endings of S ”: endings (S) $=_{\text{def}} \{x|x \text{ ends } S\}$

To illustrate, the beginnings and endings of the string *karaoke* are the sets of strings enumerated in (74).

$$(74) \quad \text{beginnings (karaoke)} = \left\{ \begin{array}{l} \emptyset \\ k \\ ka \\ kar \\ kara \\ karao \\ karaok \\ karaoke \end{array} \right\} \quad \left\{ \begin{array}{l} \emptyset \\ e \\ ke \\ oke \\ aoke \\ raoke \\ araoke \\ karaoke \end{array} \right\} = \text{endings (karaoke)}$$

The string-based notions defined in (73) provide a framework suitable for the further development of the whole family of Anchoring constraints, encompassing both segmental anchoring and anchoring constraints based on larger constituents. Concentrating here on our immediate analytical tasks, the Cross-Anchoring requirement of ZG is not that the leftmost *element* of the argot form A must correspond to the rightmost *element* of the base B: This would wrongly limit the exchange to single edge segments (attested elsewhere, see Bagemihl (1989)). What we find instead is the requirement informally depicted in (75): Some string $x \in \text{beginnings}(\text{Base})$ must correspond to some string $x' \in \text{endings}(\text{Argot})$, and conversely some string $y \in \text{endings}(\text{Base})$ must correspond to some string $y' \in \text{beginnings}(\text{Argot})$.

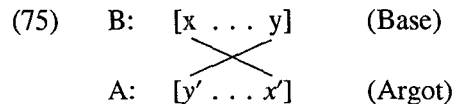

The exact length and prosodic status of the edge-strings that correspond to each other in this crosswise fashion in a given Base-Argot pairing is determined by the interaction with other constraints to be investigated below. Here we first define Cross-Anchor (Argot, Base) as in (76).

- (76) Def.: “Cross-Anchor (Argot,Base)”
 An argot form A is *cross-anchored* to a base B iff there exist strings x, y, x', y' such that
- (i) $x \in \text{beginnings}(B), y \in \text{endings}(B), x' \in \text{endings}(A), y' \in \text{beginnings}(A)$
 - (ii) $x \mathcal{R}_s x'$ and $y \mathcal{R}_s y'$
 - (iii) $x', y' \neq A, x', y' \neq \emptyset$.

(76i) amounts to the requirement that $B = x \dots y$ and $A = y' \dots x'$ (see the illustration in (75)). When Cross-Anchoring is fulfilled between A and B , we will informally call A *matched* to B , and we refer to the relevant pairs of substrings (x, x') and (y, y') as *cross-anchors*. For example, (77) illustrates how the base *karaoke* (with $x = \text{kara}, y = \text{oke}$) is matched to the argot form *okekara* (with $y' = \text{oke}, x' = \text{kara}$).

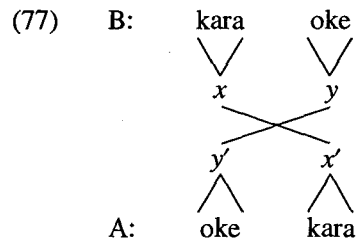

(78) shows in greater detail that the bolded string **kara**, one of the beginnings of (*karaoke*), corresponds to one of the endings of (*okekara*); and the bolded string **oke**, one of the endings of (*karaoke*), corresponds to one of the beginnings of (*okekara*), thereby fulfilling Cross-Anchoring.

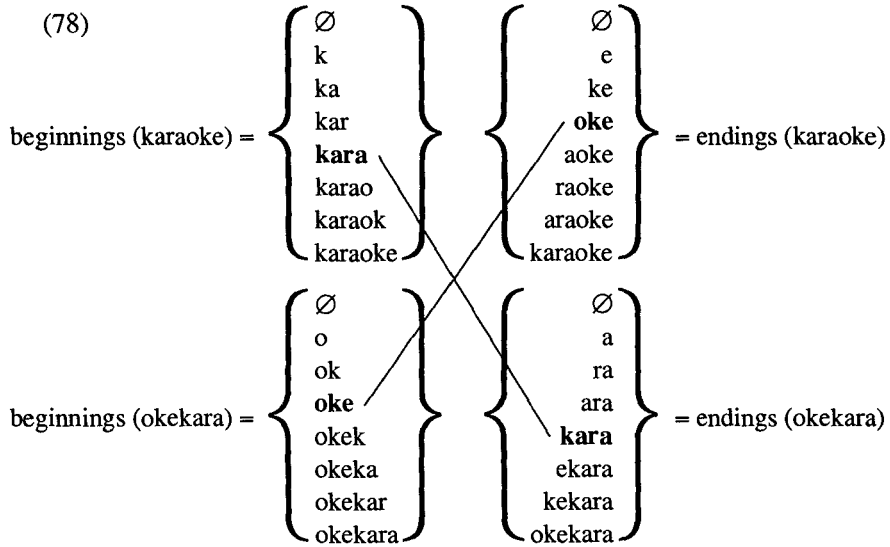

(76iii) imposes additional requirements which exclude two limit cases, namely, whole-form anchoring (of a form to itself) and empty-string anchoring. Whole-form anchoring means for an example like *karaoke* that Cross-Anchoring could be fulfilled by setting $x'=y'=karaoke$ and $x=y=karaoke$ (note that *karaoke* \in beginnings (*karaoke*) and *karaoke* \in endings (*karaoke*), as in (74)), hence trivially $x'\mathcal{R}_x$ and $y'\mathcal{R}_y$. This would mean that *karaoke* (in effect, every base) matches itself as its own argot, an obviously undesirable result.

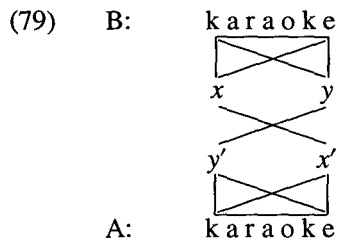

Equally undesirable would be fulfillment of Cross-Anchoring by means of empty substrings, as in (80).

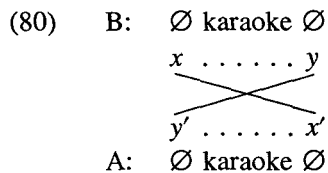

Both of these cases are ruled out by requiring that x' , y' must be nonempty proper substrings of A , as in (76iii).

Next we show that all argot forms obey Cross-Anchoring in the sense just defined, suggesting that Cross-Anchoring is not dominated by any of the other constraints under investigation here. As before, we refer to the string that stands in \mathcal{R}_s -correspondence to some string x as x' , etc., presupposing existence and uniqueness. Related base-argot pairs will have the general form in (81).

$$(81) \quad \begin{array}{l} \text{Base: } [x \dots y] \\ \text{Argot: } [y' \dots x'] \end{array}$$

An important consideration is whether Cross-Anchoring is exhaustive (i.e., “...” in (81) is the null string) or not. Exhaustive reversals are straightforward in these terms, as shown in (82) (underlining and double underlining are used as informal means of highlighting what has been reversed).

(82) Exhaustive reversal

Base	<u>ko:</u> <u>hi:</u>	<u>fu</u> <u>meN</u>	<u>kara</u> <u>oke</u>	<u>pi</u> <u>yano</u>
Argot	<u>hi:</u> <u>ko:</u>	<u>meN</u> <u>fu</u>	<u>oke</u> <u>kara</u>	<u>yano</u> <u>pi</u>

‘coffee’, ‘musical score’, ‘karaoke’, ‘piano’

In nonexhaustive reversals ((83)), the medial part – for example, *ni* in *tenisu* – does not participate in cross-anchoring, which is fulfilled by the edge strings *te* and *su* alone. Other examples in (83) cross-anchor the first (cv-) part of the initial heavy syllable, leaving behind the postnuclear moras ([i], [N], and [:]; the latter denotes a vocalic mora filled by a preceding vocalic melodeme; see section 2 for discussion regarding its moraic kana status).

(83) Nonexhaustive reversal

Base	<u>te</u> ni <u>su</u>	<u>do</u> i <u>tsu</u>	<u>pa</u> N <u>tsu</u>	<u>bi</u> : <u>ru</u>
Argot	<u>su</u> ni <u>te</u>	<u>tsu</u> i <u>do</u>	<u>tsu</u> N <u>pa</u>	<u>ru</u> : <u>bi</u>

‘tennis’, ‘German’, ‘panties/briefs’, ‘beer’

In (84) and (85), the argot form fails to faithfully preserve the vowel quantity found in the base. In our terms, these cases have a noncorresponding mora either in the base ((84)) (“shortening”) or in the argot ((85)) (“lengthening”), without affecting cross-anchoring.

- (84) Shortening reversal (= absence of corresponding mora in the argot)

Base	koma : sharu	mane : ja:	reko : da:
Argot	sharu koma	ja: mane	da: reko

'commercial', 'manager', 'recorder'

- (85) Lengthening reversal (= presence of a noncorresponding mora in the argot)

Base	me shi	ma i	pa N
Argot	shi : me	i : ma	N : pa

'food', 'dance', 'bread'

4.2. Base-Argot Faithfulness

The overall constraint system, as developed so far, is given in (86). Faithfulness (B, A), the constraint set specific to the Base-Argot realm, is subordinate to ProsodicForm, the constraints characterizing (relevant aspects of) ideal prosodic form. Faithfulness (B, A) is also subordinate to argot-specific Cross-Anchoring, which determines reversal through its domination over Linearity (the requirement that correspondence should preserve linear order).



Tableau (87) shows how this constraint system selects the candidate *da:reko* ((87a)) as the optimal argot form for the base *reko:da:* 'recorder' (here, as in later tableaux, the base is repeated for each candidate because different kinds of rearrangements need to be marked.)

(87)

	Base	Argot	Prosodic Form	Cross Anchor	Faithfulness Max- μ (B,A)
a.	<u>re</u> (ko :) (da:)	(da:) <u>re</u> ko			*
b.	re(ko:) (da:)	(da:) re(ko:)	*!		
c.	re(ko:)(da:)	(da:) re			**!
d.	re(ko :)(da:)	(reko) (da:)		*!	*
e.	re(ko :)(da:)	(ko re)(da:)		*!	*
f.	re(ko:)(da :)	(da re) (ko:)		*!	*
g.	re(ko:)(da :)	(ko:) (da re)		*!	*

(87d–g) instantiate a variety of ways in which candidates can fail to be properly cross-anchored. (87d), where the argot form is identical to its base, shows same-edge anchoring (L-to-L and R-to-R), a particularly crude violation of Cross-Anchoring. In (87e), the permutation of the first two moras (*re* and *ko*) is insufficient to fulfill Cross-Anchoring since the argot-final substring *da:* is also base-final.⁴² (87f) shows a more subtle infringement of the constraint: The fact that base-final *da:*, with a long vowel, appears argot-initially as short-vowelled *da* not only counts as a Max- μ violation but leads to a Cross-Anchoring failure (in the base *reko:da:*, the substring *da* is not an edge string). A similar violation occurs in (87g).⁴³ Cross-anchoring distinguishes these illicit shortenings from the winning candidate (87a) *da:reko*. Here the loss of the second mora of *o:* constitutes one Max- μ violation but has no disanchoring effect – it is still true that there is a string (namely, *reko*) that is right-aligned in the argot and left-aligned in the base. In contrast, (87a–c) all fulfill Cross-Anchoring; the winning candidate (87a) is superior to (87b) because the latter, with its ternary FoF structure, fails on ProsodicForm; it is superior to (87c) by one Max- μ violation (in addition, (87c) is afflicted with fatal Max-Seg violations not depicted in this tableau, see below).

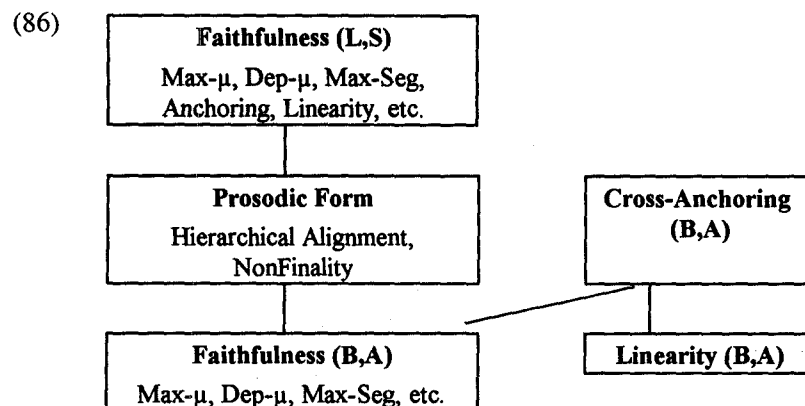
The general picture that emerges from (87) is the following: Violations of Cross-Anchoring ((87d–g)) are fatal, as are violations of Prosodic Form ((87b)). Among the forms satisfying both sets of constraints, the one that is most faithful to the base is selected as the winning candidate. In this way, the optimality-theoretic principle of minimal violation succeeds in subsuming the idea of ‘reversal with minimal distortion’ that is constitutive of the ZG-argot and of other reversing language games.

With the general constraint framework in place, we will now fill in further details, beginning with a more fine-grained analysis of faithfulness-related

issues. As documented in section 2.4 above, the argot imposes strict limits on the kinds of compression that are permissible in producing a prosodically impeccable ZG-form. In particular, segment deletion is not a way of arriving at a ZG-correspondent for long words like *kurisumasu* ‘Christmas’ – such examples rather lack a ZG form altogether. This systematic aspect of the argot results from the internal structure of the BA-Faithfulness block given in (88).

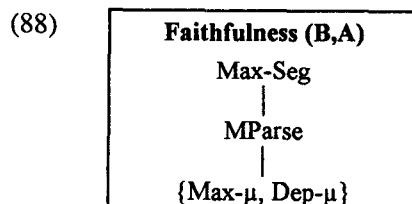

In (88), the constraint MParse⁴⁴ (Prince and Smolensky (1993, 49)) – in this case insisting on the morphological parsing, in surface structure, of what can be thought of as a category “ZG” – is subordinated to the constraint Max-Seg (militating against the loss of any base segment in the argot form). The ZG-forms looked at so far all trivially fulfill MParse in that the category ZG is part of the morphological output structure: [*hi:ko:*]_{ZG} (< *ko:hi*: ‘coffee’), [*sunite*]_{ZG} (< *tenisu* ‘tennis’), [*da:reko*]_{ZG} (< *reko:da*: ‘recorder’), etc. A violation of MParse for the category ZG, informally indicated by “Ø” in (89a), characterizes a candidate with a null ZG-form. Due to the ranking of MParse below Max-Seg, the null candidate turns out to be the winner for the 5 μ -form *kurisumasu* ‘Christmas’ (89).

(89)

Base	Argot	Pros Form	Cross Anchor	Faithfulness (B,A)		
				Max-Seg	MParse	Max- μ
a. ☞ (kuri)su(masu)	Ø				*	
b. (kuri)su(masu)	(masu)(kuri)su	*!				
c. (kuri)su(masu)	(masu)(kuri)			su!		*

Candidate (89b) preserves all base material, fatally violating Prosodic form, and (89c) has a Max-Seg violation that marks it as inferior to the null candidate ((89a)). Given the lack of any output, (89a) violates neither ProsForm nor CrossAnchoring.

The tableau for *akademi*: ‘academy’ ((90)) motivates the ranking of Cross-Anchoring above MParse.

(90)

Base	Argot	Pros Form	Cross-Anchor	Faithfulness (B,A)		
				Max-Seg	MParse	Max-μ
a. \emptyset (aka)de(mi:)	\emptyset				*	
b. (aka)de(mi:)	(mi:) (aka)de	*!				
c. (aka)de(mi:)	(demi) (aka)		*!			*
d. (aka) de (mi:)	(mi:) (aka)			de!		*

Here the two shortening candidates ((90c) and (90d)) are revealing: The first permutes a non-edge string (namely, *demi*, which excludes the second mora of *i*) and hence fails to cross-anchor; the second achieves cross-anchoring at the cost of a fatal Max-Seg violation.

In a parallel manner, (91) shows for the 6μ-base *su:pa:maN* ‘superman’ how the null output violating MParse bests other – overt – candidates that violate higher-ranking constraints.

(91)

Base	Argot	Pros Form	Cross-Anchor	Faithfulness (B,A)		
				Max-Seg	MParse	Max-μ
a. \emptyset (su:)(pa:)(maN)	\emptyset				*	
b. (su:)(pa:)(maN)	(maN)(su:)(pa:)	*!				
c. (su:)(pa:)(maN)	(maN)(pa:)(su:)	*!				
d. (su:)(pa:)(maN)	(maN)(supa)		*!			**
e. (su:)(pa:)(maN)	(maN)(su:)			pa!		**

(91) demonstrates how severely Cross-Anchoring limits the shortening possibilities. The segmentally impeccable but moraicly truncated argot candidate *maNsupa* (91d) is disqualified not because of the double mora loss per se but because one of the moras is lost in a sensitive location: The right-edge substring *supa* in the argot candidate does not cross-anchor to the left-edge substring *su:pa* in the base. The discrepancy in their internal moraic composition means that the two do not even stand in correspondence as strings (see (70) above). In terms of the scheme for base-argot anchoring used earlier (and here repeated in (92)), this means that a truncated mora can never be localized inside the cross-anchoring pairs of edge strings (*x, x'*) and (*y, y'*).

(92)

Base: a.	[x ... y]	b. [reko : da:]	c. [sa ke]
Argot:	[y' ... x']	[da: reko]	[ke : sa]

This leaves only word-medial position (indicated by “. . .” in (92a)) as a locus for potential mora truncation, where it is indeed found (as shown in (92b), taking up an earlier example (87)).

Word-medial position is also the only location where a non-corresponding mora is tolerated in the other direction, i.e., a mora present in the ZG-form that has no correspondent in the Base. The forms falling under this description are cases of lengthening as in (92c) *ke:sa* (< *sake*) (see section 2.1 for further examples). (93) makes it clear that the rationale for lengthening in such cases lies in the prosodic form constraints.

(93)

	Base	Argot	ProsForm	CrossAnch	Dep- μ
a.	<u>sa</u> <u>ke</u>	(<u>ke</u> :) <u>sa</u>			*
b.	(<u>sa</u> <u>ke</u>)	(<u>ke</u> <u>sa</u>)	*!		
c.	(<u>sa</u> <u>ke</u>)	(<u>ke</u> :) (<u>sa</u> :)		*!	**

Candidate (93b), which simply permutes the two syllables without introducing an extra mora, consists of a single foot and hence violates the prosodic form constraint NonFinality(F') (see section 3). In contrast, (93a), the winning candidate, consists of a monosyllabic foot (filled through lengthening, a Max- μ violation) followed by a final unfooted syllable. (93c) shows the impossibility of noncorresponding moras at edges (here instantiated by mora addition in argot-final position). Even though the doubly lengthened (*ke:)(sa:)* obeys NonFin(F') while also ensuring smooth footing without a loose syllable, it loses against (93a) because the argot-final extra mora is fatally disanchoring (*sa* is not an edge string in the argot form).

Monomoraic bases show a doubling of the vowel melody: *hi* ~ *i:hi*, *me* ~ *e:me* etc. (see (94) and section 2.1 above). Here a single element in the base has two correspondents in the argot (indicated by coindexation – compare the representation by means of spreading in Tateishi (1989, 396–397)).

(94)

Base	h _i i _j	m _i e _j
Argot	i _j : h _i i _j	e _j : m _i e _j

‘cigarette light (lit.: fire)’, ‘eye’

Whenever a single element has more than one correspondent, the correspondence itself is not univalent.⁴⁵ Taking up a term familiar from syntactic theory in a related sense, we will refer to the constraint violated in (94) as Bijectivity.⁴⁶ In the overall ranking of constraints, Bijectivity is subordinate to Cross-Anchoring (see (96) below).

Monomoraic bases raise an interesting question: How do their associated ZG-forms manage to fulfill Cross-Anchoring? For example, which substrings of *hi* does *i:hi* cross-anchor to? The answer is that in these cases the analysis imposed on the base by the argot yields overlapping substrings *x*, *y* as cross-anchoring elements ((95a)). The inclusion relation between the substrings is graphically illustrated in (95b).

(95) a.

Base	<u>h</u> i	$x=hi, y=i$
Argot	i : <u>hi</u>	$y'=i, x'=hi$



Tableau (96) shows how the correct argot form is selected for this example.⁴⁷

(96)

	Base	Argot	ProsForm	CrossAnch	Bijectivity	Dep- μ
a. ✖	(<u>h</u> i)	(i :) <u>hi</u>			i	**
b.	(<u>h</u> i)	(i <u>hi</u>)	*!		i	*
c.	(<u>h</u> i)	(<u>hi</u> :) <u>hi</u>			hi!	**

‘cigarette light (lit.: fire)’

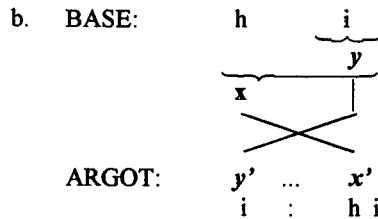
Other types of short bases reveal further details about the constraint system and indicate which phonological constraints are crucially dominated by Cross-Anchoring. Thus nasal-closed heavy syllable bases such as *paN* ‘bread’ have argot forms (*N: pa*) that violate the constraint against nuclear nasals (*Nuc/Nas)(97). Here the fact that (97a) wins over (97b) shows that Bijectivity dominates *Nuc/Nas (see the analysis of Berber in Prince and Smolensky (1993)).

(97)

	Base	Argot	Bijectivity	*Nuc/Nas
a.	$\text{pa} \underline{\underline{N}}$	$(\underline{\underline{N}} :) \underline{\underline{pa}}$		*
b.	$(\underline{\underline{pa}} \underline{\underline{N}})$	$(\underline{\underline{aN}}) \underline{\underline{pa}}$	a!	

‘bread’

Bases consisting of a single superheavy syllable are all nasal-closed and come in two varieties, $cv:N$ and $cv_i v_j N$. Among other factors, the dominance of Bijectivity over *Nuc/Nas predicts that the two will be treated differently in the argot. For a long-vowelled base such as $to:N$ ‘tone’, doubling the vowel ((98b)) violates Bijectivity (and arguably also Cross-Anchoring), hence the argot form $N:to$, with a nuclear nasal, comes out as optimal ((98a)), in spite of a *Nuc/Nas violation. For bases with two vowel segments such as $saiN$ ‘sign’, Bijectivity is not an issue, so *Nuc/Nas chooses $iNsa$ ((98d)) over $N:sai$ ((98c))(the latter also suffers from a Dep- μ violation not shown in the tableau).

(98)

	Base	Argot	Bijectivity	*Nuc/Nas
a.	$(\underline{\underline{to}} : \underline{\underline{N}})$	$(\underline{\underline{N}} :) \underline{\underline{to}}$		*
b.	$(\underline{\underline{to}} : \underline{\underline{N}})$	$(\underline{\underline{oN}}) (\underline{\underline{to}})$	o!	
c.	$(sa \ iN)$	$(N :) (sai)$		*!
d.	$(sa \ iN)$	$(iN) sa$		

‘tone’, ‘sign’

The bisyllabic base $pata:N$ ‘pattern’ ((99)), which ends in a $cv:N$ syllable, behaves like $to:N$ in (98).⁴⁸

(99)

	Base	Argot	Bijectivity	*Nuc/Nas
a.	$(\underline{\underline{pata}} : \underline{\underline{N}})$	$(\underline{\underline{N}} :) \underline{\underline{pata}}$		*
b.	$(\underline{\underline{pata}} : \underline{\underline{N}})$	$(\underline{\underline{aN}}) (\underline{\underline{pata}})$	a!	

‘pattern’

In conclusion to this section, (100) assembles the constraints that have played a role in the analysis so far and indicates the most important ranking relations between them.

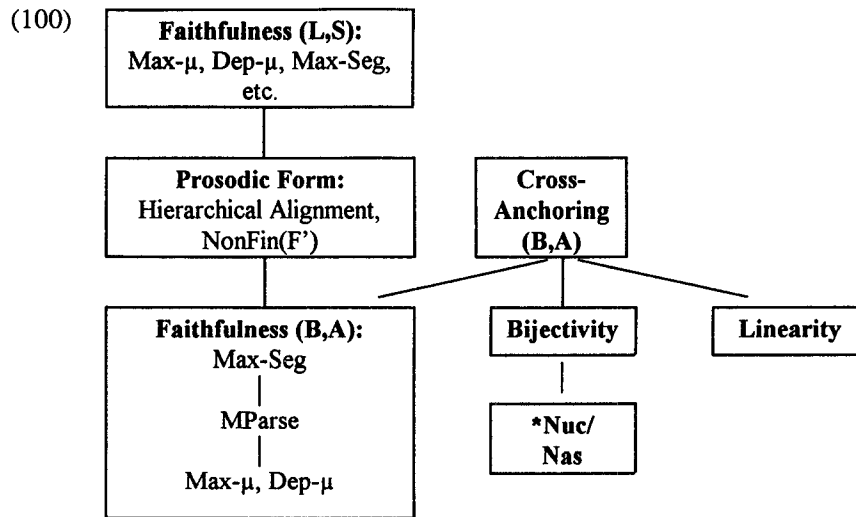

5. PRESERVATION OF PROSODIC STRUCTURE

B(ase)-A(rgot) and L(exical)-S(urface) Faithfulness not only occupy separate places within the constraint hierarchy, they also differ in the degree to which higher prosodic structure is taken into account. As first explicated in terms of Correspondence Theory by McCarthy (1995) in a related context, the second point is a direct consequence of the nature of the input representations with respect to which output evaluation takes place. In Base-Argot relations, B is a fully articulated phonological representation, equipped with all details of syllable and foot structure; on the other hand, Lexical-Surface relations are shaped by the sparse prosodification of L. In the standard conception,⁴⁹ L contains the unpredictable aspects of items (segments with associated moras encoding length and gemination) but is free of the predictable aspects of all higher prosody structure (σ , F, PrWd, etc.).

Within any domain, a constraint such as Max-Foot (MaxFt) is violated by any input-output pairing that does not faithfully preserve the foot-sized constituents of the input in the output, in a sense made precise in (101a); the corresponding DepFt is violated by any foot-sized constituent of the output that is not grounded in the input, as defined in (101b). As discussed in section 3, these constraints are situated within the general conception of faithfulness (McCarthy and Prince (1995), 122) centered around Max and Dep (see (46) for the definitions adopted here).

(101) Let I, O be pairs of linguistic representations connected by some linguistic process as input and output; let $x \subseteq_s I, y \subseteq_s O$ (substrings), and let \mathcal{R} be a correspondence relation on I, O and \mathcal{R}_s , its string extension (as defined in (70)).

a. MaxFt

\mathcal{R} and \mathcal{R}_s are foot-structure-preserving in direction I-O: Substrings of I that are feet correspond to substrings of O that are feet.

$$\forall xy [x\mathcal{R}_s y \wedge \text{Ft}(x)] \rightarrow \text{Ft}(y)^{50}$$

b. DepFt

\mathcal{R} and \mathcal{R}_s are foot-structure-preserving in direction O-I: Substrings of O that are feet correspond to substrings of I that are feet.

$$\forall xy [x\mathcal{R}'_s y \wedge \text{Ft}(y)] \rightarrow \text{Ft}(x)$$

Candidate I, O pairings can fail MaxFt in different ways, some resulting in more drastic deviations from foothood than others. We demonstrate below that the ZG-Argot needs more fine-grained measures of prosodic faithfulness (as proposed in McCarthy (1995) and work cited therein).

For the LS domain, the prosodic bareness of L means that there is little to be faithful to in the I-O direction; MaxFt can play only a very marginal role, namely in cases where exceptions are encoded by means of lexical prosodic structure (see, e.g., Inkelas (1994a) on exceptional foot marking; cf. also Hammond (1995)). In the BA domain, both base and argot are phonological surface representations, equipped with fully-formed prosodic structure; hence Faithfulness to higher prosodic constituency is of prime importance here. Similar reasoning led to the proposal in IKM (1992, 7) that ZG-mapping must preserve the “prosodic type” of the base, a requirement that presupposes prosodification of both argot and base in order to make any sense, i.e., as a surface-surface requirement. Prosodic Faithfulness in the BA domain is an explication and development of this informal notion of Prosodic Type Preservation; as hypothesized in the earlier work, we find Faithfulness beyond the segmental and moraic levels to be crucial in determining the winning candidate for many bases.⁵¹

5.1. Prosodic Faithfulness

Even in the descriptively simplest cases of the ZG argot, namely F-F reversals such as $(kara)(oke) \rightarrow (oke)(kara)$, foot faithfulness plays a decisive role since, as we will now show, Cross-Anchoring and the prosodic

form constraints underdetermine the selection of the winning candidate. Within the LS domain, the nonprosodified lexical input /karaoke/ is mapped, under the control of the prosodic wellformedness constraints, to the fully footed S-representation (kara)(oke). Within the BA domain, this fully footed representation takes on the role of B in ZG-candidates. The tableau in (102) presents a number of different B-A candidate pairings.

(102)

	Base	Argot	Pros Form	Cross Anch	MaxFoot	DepFoot
a.	<u>ka</u> <u>ra</u>	(kara) (oke) (oke) (kara)				
b.	(ka ra)(o ke)	(ke ra)(oka)			*(kara), *(oke)	*(kera), *(oke)
c.	(ka ra) (oke)	(rao)(ke ka)			*(kara), *(oke)	*(rao), *(keka)
d.	(ka ra)(oke)	(ra ka)(oke)		*!		

The first three candidates all fulfill ProsForm and Cross-Anchoring. (102a) wins over (102b,c) because it is most faithful to the input footing: Both foot-sized constituents of B are preserved in A, albeit in reversed order, and A contains no foot-sized constituents alien to B. In (102b), the non-exhaustive reversal of *ka* and *ke* fulfills Cross-Anchoring but leads to an unfaithful reshuffling of the contents of feet: Neither (*kara*) nor (*oke*) appear in A (**MaxFt); instead we encounter (*kera*) and (*oka*) (**DepFt). In (102b), as in the other candidates, A is exhaustively footed into two feet, and therefore each MaxFt violation is accompanied by a corresponding DepFt violation (informally: in place of every B-foot that is missing, A has a different foot that is in turn not found in B). In (102c), the reversal of the mora *ka* with the nonconstituent string *raoke* leads to similar foot faithfulness violations. The last candidate, (102d), fails because it violates undominated Cross-Anchoring.

In this analysis, then, the Highest Parse constraint proposed in IKM (1992, 11–15) has the status of a theorem – it is reduced to the joint effect of Cross-Anchoring and Foot Faithfulness. Reversing the two immediate constituents of the word is optimal because it cross-anchors the argot with full preservation of the foot structure of the base.

A closer look reveals, however, that MaxFt and DepFt are not quite appropriate, and in any case are not sufficient, as measures of foot faithfulness. A first hint in this direction comes from the fact that (102d) above, while violating Cross-Anchoring, manages to fulfill MaxFt and DepFt in a surprising way: (kara)*R'*(raka), in spite of the foot-internal reversal, and the segmental material {k,a,r,a}, taken as a whole, makes a foot in both B and A. The need for more fine-grained measures of foot-structural

detail becomes imperative when we consider cases like (103), where the two candidates (*shi:*)(*taku*) and (*shi:*)(*kuta*) tie in all relevant respects: Cross-Anchoring, Prosodic Form, MaxFt and DepFt.

(103)

	Base	Argot	ProsForm	CrossAnch	MaxFoot	DepFoot
a. *!	(<u>taku</u>) (<u>shi:</u>)	(<u>shi:</u>)(<u>taku</u>)				
b.	(<u>ta ku</u>)(<u>shi:</u>)	(<u>shi:</u>)(<u>ku ta</u>)				

'taxi'

In (103a), the B-feet (*taku*) and (*shi:*) are preserved in the argot, thus fulfilling MaxFt. In (103b), the B-foot (*shi:*) is found in the argot; and the string-correspondent of the B-foot (*taku*) is the A-foot (*kuta*), fulfilling MaxFt with corresponding – albeit reordered – segments. Viewed from the argot side, parallel considerations show that DepFt is fulfilled in both (103a) and (103b).

One possible line of attack would be to develop a more elaborate system of penalties for linearity violations. For example, Linearity could take into account at what prosodic level precedence structure is violated. This would give the edge to (103a), which violates Linearity only at the PrWd level (**shi:<taku*), over (103b), which suffers from an additional Linearity violation at the Ft level (**ku<ta*). We will here pursue a different line, one which has proved useful in other areas of analysis (see McCarthy (1995) on prosodic circumscription effects and lexically specified foot structure): instead of treating foot faithfulness as an all-or-nothing affair, as in (101a,b) above, it is made sensitive to the foot-internal positions occupied by segmental material. Within any foot with binary structure at some level of analysis, we can distinguish a head role and a tail (nonhead) role (this term is due to McCarthy (1995)). In a bimoraic trochee, these coincide with the first and second mora of the foot, respectively. Prosodic faithfulness is a measure of the degree to which corresponding segments occupy equivalent foot positions. Letting *x* and *y* be substrings of I and O, respectively, and letting \mathcal{R}_s denote the string-correspondence induced by some correspondence \mathcal{R} (see (70) in section 4), we will assume the following faithfulness constraints:

(104) a. MaxFtHead

\mathcal{R}_s is foothead-preserving in direction I-O: Substrings of I that are footheads correspond to substrings of O that are footheads.

$$\forall x[x\mathcal{R}_s y \wedge \text{FtHead}(x)] \rightarrow \text{FtHead}(y)$$

b. MaxFtTail

\mathcal{R}_s is foottail-preserving in direction I-O: Substrings of I that are foottails correspond to substrings of O that are foottails.

$$\forall x [x\mathcal{R}_s y \wedge \text{FtTail}(x)] \rightarrow \text{FtTail}(y)$$

c. DeptFtHead

\mathcal{R}_s is foothead-preserving in direction O-I: Substrings of O that are footheads correspond to substrings of I that are footheads.⁵²

$$\forall y [x\mathcal{R}_s y \wedge \text{FtHead}(y)] \rightarrow \text{FtHead}(x)$$

d. DeptFtTail

\mathcal{R}_s is foottail-preserving in direction O-I: Substrings of O that are foottails correspond to substrings of O that are foottails.

$$\forall y [x\mathcal{R}_s y \wedge \text{FtTail}(y)] \rightarrow \text{FtTail}(x)$$

Tableau (105) applies this new conception of foot-structural faithfulness to the example *takushi:*, where undifferentiated MaxFt and DeptFt had failed before (see (103)). As expected, sensitivity to prosodic role makes the correct distinction. The notation “*(. . .)” indicates a violation of the Head role, and “*. . .)” a violation of the Tail role. For example, “*(*ta*” in (105b) records the fact that the mora *ta* occupies Head position in the base (*taku*)(*shi:*) but not in the argot candidate (*shi:*)(*kuta*).

(105)

	Base	Argot	MxFtHd	MxFtTail	DpFtHd	DpFtTail
a.	(<i>taku</i>) (<i>shi:</i>)	(<i>shi:</i>) (<i>taku</i>)				
b.	(<i>ta ku</i>)(<i>shi:</i>)	(<i>shi:</i>) (<i>ku ta</i>)	*(<i>ta</i>	* <i>ku</i>)	*(<i>ku</i>	* <i>ta</i>)

‘taxi’

Making prosodic faithfulness sensitive to foot-internal prosodic roles will be crucial for some of the forms to be discussed later. A reasonable question to ask at this point is whether all important effects of the earlier macro-level foot faithfulness constraints MaxFt and DepFt are indeed covered by the conjunction of the micro-constraints in (104). A moment’s reflection reveals that this cannot be the case. Concentrating on the Max constraints, consider the hypothetical situation indicated in (106), where double epenthesis of *ta* in the output has broken up the input foot (*puki*).

(106) I: (pu ki)
 O: (pu **ta**) (**ta** ki) MaxFtHead: ✓ MaxFtTail: ✓

Here every input mora corresponds to an output mora with the same prosodic role – (*pu* \mathcal{R}' (*pu*, and *ki*) \mathcal{R}' *ki*), – in spite of the fact that the input foot (*puki*)

is not at all preserved in the output (and since the epenthetic *ta* sequences stand outside of all correspondence, the DepFt-constraints are not violated either). In order to complete the picture of prosodic faithfulness in (104a–d), some constraint is needed that provides an incentive for footmates to remain footmates. This is not surprising: Group-level predicates (like “is-a-foot”) cannot be directly replaced by individual-level predicates in this way without loss of information (a foot is more than a set of segmental objects, each equipped with a foot-role). A simple, though perhaps not the most elegant, option is to confront the issue directly by means of the constraints formulated in (107), which make use of the term “tautopodic” (cf. “tautosyllabic”) to denote the property of being part of one and the same foot.

- (107) a. MaxTautoPod $(x_1, x_2 \subseteq_s I \text{ and } y_1, y_2 \subseteq_s O)$
 \mathcal{R}_s is tautopodicity-preserving in direction I-O: I-footmates correspond to O-footmates.

$$\forall x_1, x_2, y_1, y_2 [\text{TautoPod}(x_1, x_2) \wedge x_1 \mathcal{R}_s y_1 \wedge x_2 \mathcal{R}_s y_2] \\ \rightarrow \text{TautoPod}(y_1, y_2)$$

- b. DepTautoPod
 \mathcal{R}_2 is tautopodicity-preserving in direction O-I: O-footmates correspond to I-footmates.

$$\forall x_1, x_2, y_1, y_2 [\text{TautoPod}(y_1, y_2) \wedge x_1 \mathcal{R}_2 y_1 \wedge x_2 \mathcal{R}_2 y_2] \\ \rightarrow \text{TautoPod}(x_1, x_2)$$

Returning to our main analytical task, an extension of the analysis beyond F-F reversals of bipodal bases reveals that prosodic faithfulness constraints by no means go unviolated in the ZG-Argot. This is the expected result since Prosodic Role Faithfulness, similar to the other B-A faithfulness constraints, is dominated by ProsForm. In (108a)⁵³ the B-foothead (*ma* does not correspond to an A-foothead (but rather to an A-foottail), and a similar violation is observed in (108c) for the B-foothead (*me*, which corresponds to an unfooted substring of A. In addition, (108a) incurs a violation of Max- μ , and (108c) a violation of Dep- μ . However, (108a) and (108c) are still optimal because the rivalling candidates listed – (108b) and (108d) – while consummately faithful to the foot-related prosody of the base, fatally violate the higher-ranking Prosodic Form constraints (Hierarchical Alignment and Nonfinality, respectively).

(108)

	Base	Argot	ProsForm	MaxFtHd
a.	<u>ko</u> (<u>ma :</u>)(<u>sharu</u>)	(<u>sharu</u>) (<u>koma</u>)		*(<u>ma</u>)
b.	<u>ko</u> (<u>ma:</u>)(<u>sharu</u>)	(<u>sharu</u>) <u>ko</u> (<u>ma:</u>)	*!	
c.	(<u>me</u> <u>shi</u>)	(<u>shi :</u>) <u>me</u>		*(<u>me</u>)
d.	(<u>me</u> <u>shi</u>)	(<u>shi</u> <u>me</u>)	*!	

‘commercial’, ‘food’

5.2. Prosodic Role Preservation

Recall from section 2 (see (18)–(19)) that the argot formation of 3μ-forms falls descriptively into two types: (i) [1] [23] → [23] [1] (“exhaustive reversal”) and (ii) [1] 2 [3] → [3] 2 [1] (“nonexhaustive reversal”). We will here see that prosodic faithfulness constraints account for the systematic differences.

Starting with LH bases, we see that the candidate pair ((109a)), with an exhaustive reversal of the L-syllable and the H-syllable (the latter constituting a bimoraic foot), preserves foot structure perfectly and at the same time results in a desirable prosodic form. Hence no other candidate is a serious competitor.

(109) Base = [L (H)]

	Base	Argot	ProsForm	MaxFtHd
a.	<u>ma</u> (<u>zui</u>)	(<u>zui</u>) <u>ma</u>		
b.	<u>ma</u> (<u>zu</u> <u>i</u>)	(<u>i</u> <u>zu</u>) <u>ma</u>		*(<u>zu</u> !)
c.	<u>ma</u> (<u>zu</u> <u>i</u>)	<u>i</u> (<u>mazu</u>)	*!	*(<u>zu</u>)

‘unsavory’

For lexical LLL inputs whose surface representation is prosodified with a right-edge foot, i.e., [L(LL)], the Base-Argot correspondence proceeds along parallel lines. Just as in the case of the [L(H)]-base ((109)), the optimal candidate shows an exhaustive reversal of the two immediate constituents of the word, the L-syllable and the LL foot ((110)).

(110) Base = [L (LL)]

	Base	Argot	ProsForm	MaxFtHd
a.	<u>ko</u> (<u>domo</u>)	(<u>domo</u>) <u>ko</u>		
b.	<u>ko</u> (<u>do</u> <u>mo</u>)	(<u>mo</u> <u>do</u>) <u>ko</u>		*(<u>do</u> !)
c.	<u>ko</u> (<u>do</u> <u>mo</u>)	(<u>mo</u> <u>ko</u>) <u>do</u>		*(<u>do</u> !)

‘child’

The question that remains to be answered, then, is why the base form in (110) has a right-anchored foot in the first place, a prosodification that is remarkable in view of the fact that Nonfinality(F') is demonstrably operative in the grammar of Japanese. This question must be answered within the LS domain since the base for the argot is simply the prosodified surface structure. For the case at hand, the reason can be traced to the internal morphological constituent structure of the word, which consists of two separate morphemes: /ko|+/domo/. High-ranking alignment requirements between MCat and PCat, crucially dominating NonFinality, force a right-aligned surface foot built so as to coincide with the morphological structure (111).⁵⁴

(111)

	Lexical	Surface	MCat-PCat Align	NonFin
a. ☞	/ko domo/	ko (domo)		*
b.	/ko domo/	(ko do) mo	*!	

The upshot is that exhaustive reversal (of the two immediate constituents of PrWd) is optimal for trimoraic bases with right-anchored feet – [L(H)] or [L(LL)] – because foot role faithfulness is maximally observed.

On the other hand, in the case of bases with left-anchored feet – [(H)L] or [(LL)L] – the same kind of exhaustive reversal would lead to a violation of NonFinality in the argot form ((112a)). Even though the exhaustively reversed candidate (112a) does not violate any of the prosodic faithfulness constraints (the tableau shows Dep- μ and Max FtHd for illustration), it goes out of competition at the early ProsForm stage, losing to the candidate pairs (112b,c).

(112) Base = [(H) L]

	Base	Argot	ProsForm	Dep- μ	MaxFtHd
a.	(paN) <u>tsu</u>	<u>tsu</u> (paN)	*!		
b. ☞	(pa N) <u>tsu</u>	(<u>tsu</u> N) pa			*(pa
c.	(paN) <u>tsu</u>	(tsu :) (paN)		*!	

'panties/briefs'

The two candidates (112b) and (112c) establish the ranking Dep- μ >> MaxFtHd: Avoiding mora epenthesis is more important than faithfully preserving the foot-head status of (pa. Another potential argot candidate *Ntsupa* loses because of the high-ranking *Nuc/Nas constraint discussed in the previous section.

Making prosodic faithfulness sensitive to foot-internal prosodic roles

becomes crucial in accounting for other trimoraic cases. In the examples discussed so far ((109), (110), and (112)), the optimal candidate would win even if prosodic role faithfulness was replaced by the single global constraint MaxFt ((101a)). That this is not always the case in trimoraic forms is demonstrated by tableau (113), where both (113b), the intended winner, and (113c) show one violation of MaxFoot: the base foot *tai* is absent in the argot.

(113) Base = [(H) L]

	Base	Argot	ProsForm	MaxFoot
a.	(<u>ta i</u>) <u>pu</u>	<u>pu</u> (<u>ta i</u>)	*	
b.	* (<u>ta i</u>) <u>pu</u>	(<u>pu i</u>) <u>ta</u>		*(<u>ta i</u>)
c.	(<u>ta i</u>) <u>pu</u>	(<u>i pu</u>) <u>ta</u>		*(<u>ta i</u>)

‘type’

The trouble with MaxFt is that it treats the total foot-structural divergence in (113b), where both (*ta* has lost its head role and *i*) its tail role, on a par with partial divergence in (113c), where (*ta* has lost its head role but *i*) has preserved its tail role. The small but important difference between the two is teased out by the foot-role constraints, as shown in (114). The distinguishing factor here is the preservation of the tailhood of *i*, giving the decisive edge to the nonexhaustively reversing candidate in (114b) over the exhaustively reversing alternative in (114c).

(114) Base = [(H) L]

	Base	Argot	ProsForm	MaxFtHead	MaxFtTail
a.	(<u>ta i</u>) <u>pu</u>	<u>pu</u> (<u>ta i</u>)	*!		
b.	* (<u>ta i</u>) <u>pu</u>	(<u>pu i</u>) <u>ta</u>		*(<u>ta</u>	
c.	(<u>ta i</u>) <u>pu</u>	(<u>i pu</u>) <u>ta</u>		*(<u>ta</u>	*(<u>i</u>)!

An exactly parallel explanation accounts for the selection of the non-exhaustive reversal candidate for trimoraic (LL)L with a left-anchored foot (115).

(115) Base = [(LL) L]

	Base	Argot	ProsForm	MaxFtHead	MaxFtTail
a.	(<u>teni</u>) <u>su</u>	<u>su</u> (<u>te ni</u>)	*!		
b.	* (<u>te ni</u>) <u>su</u>	(<u>su ni</u>) <u>te</u>		*(<u>te</u>	
c.	(<u>te ni</u>) <u>su</u>	(<u>ni su</u>) <u>te</u>		*(<u>te</u>	*(<u>ni</u>)!

‘tennis’

Here the candidate (115b) wins because the foottail-role of the medial syllable *ni* remains constant, whereas in (115c), even though both the base foot (*teni*) and the argot foot (*nisu*) contain the syllable *ni*, its prosodic role is drastically different.⁵⁵

To sum up, it is the interaction of the prosodic form constraints with prosodic role faithfulness that explains why exhaustive reversal in the argot correlates with right-edge footing in the base and nonexhaustive reversal with left-edge footing. As far as the footing of the base itself is concerned, it is a direct function of the position of the H-syllable in L(H) and (H)L. For LLL bases, the footing is determined by the normal Lexical-Surface correspondence of Japanese (and not by the Base-Argot correspondence). The prosodic constraint NonFinality determines (LL)L as the default – unless it is overridden by other more important factors, such as the alignment factors induced by morphological constituency discussed in connection with (111) above. There appear to be a number of additional factors forcing the nondefault footing L(LL), including the preference to place *r* in foot medial position (e.g., /*kusuri*/ →_{L,S} *ku(suri)* →_{B,A} (*suri*)*ku* ‘drugs’).⁵⁶ Further empirical investigation, including non-ZG evidence, is needed to validate such tendencies. Here we will simply assume, for descriptive purposes, that cases of L(LL)-footing in the base (such as *pi(yano)*) not attributable to any known preference have a lexical foot inscribed in their lexical structure, which is faithfully transmitted to the surface form (i.e., /*pi(yano)*/ →_{L,S} *pi(yano)* →_{B,A} (*yano*)*pi*).

The ranking relations between the BA-faithfulness constraints summarized in (116) show that in terms of the assessment of input/output disparities, segments count for more than moras in this case (as in many others), which are in turn more significant than footing relations. But, as we have seen for trimoraic forms, even the low-ranking foot role constraints have the power to cast the tie-breaking vote selecting the winning candidate when the other constraints do not lead to a decision.

(116)

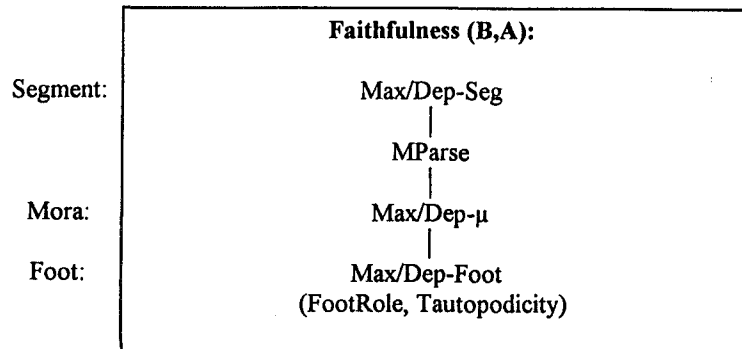

6. SUMMARY AND FURTHER ISSUES

This section summarizes the major points of our ZG analysis, focussing on the overall typology of attested reversals. We also tie up several loose ends and offer some speculative solutions regarding further issues not dealt with so far. In recapitulating the primary results, we extensively refer back to the relevant sections of the paper so that the reader can verify the details of the analysis and argumentation.

The defining characteristic of the ZG-argot is the cross-anchoring of base and argot, depicted in (117) in a schematic form (a formal definition is given in section 4; see (76) and the surrounding discussion.)

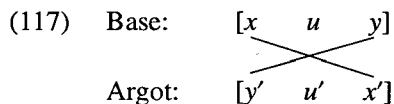

In this scheme, edge strings and medial strings have a very different status. While the existence of corresponding edge strings (y, y') and (x, x') is essential to the satisfaction of the Cross-Anchoring constraint, the contents of the medial strings u and u' help distinguish several different types of reversals, as in (118).

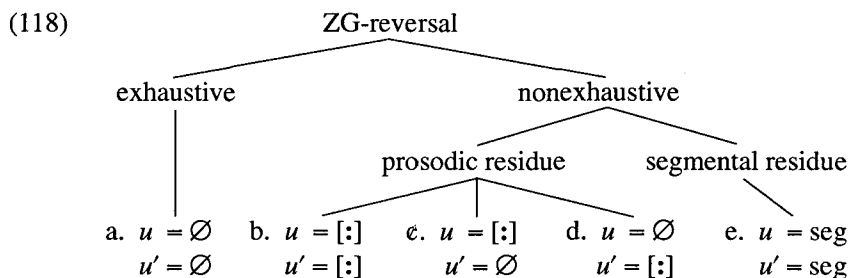

Exhaustive reversal ((118a)) constitutes the prototype of the ZG-argot. It is found with bases of the forms F+F ((119a)) and L+F ((119b)), (i.e., x is either a foot or a light syllable, and y is a foot). A switch of the two immediate constituents of PrWd constitutes the optimal form, fulfilling the high-ranking ProsForm constraints (see the discussion in section 3).

(119) Exhaustive reversals ($u=u'=Ø$, (118a))

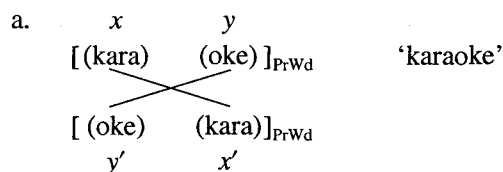

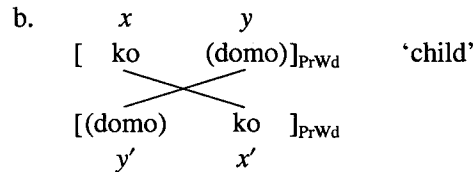

A special subtype of exhaustive reversals arises with monosyllabic CV: and CV bases ((120)).

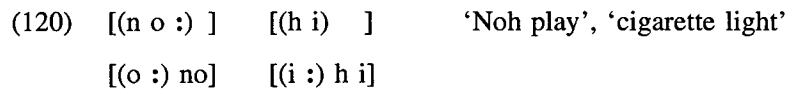

Such forms receive an analysis as in (121), with overlapping y , x factors. The vowel melodeme of B has multiple correspondents in A, violating Bijection (see the discussion in section 4, (94)–(96)).

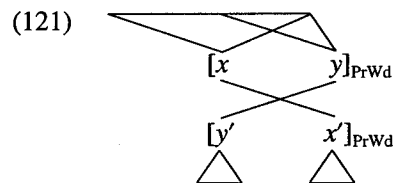

The existence of (120) and similar examples raises the question of whether there are limits on factor overlap: In the extreme case, is complete overlap permitted (i.e., $y = x$)? It appears that this is not the case. Some relevant evidence comes from the behavior of monosegmental bases, as in (122).

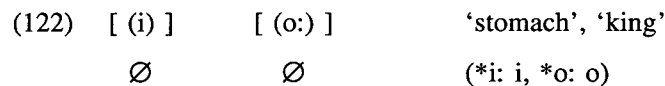

Here a single vocalic element (prosodically long or short) makes up the whole melodic substance of the base. Instead of spreading this single melodeme out over the whole form (*i:i, etc.), such bases have null ZG-outputs (see note 12 in section 2 for additional examples). This suggests that there is some restriction (plausible on functional grounds) to the effect that the melodic contents of y and x cannot be entirely identical (on this point, see also Tateishi (1989, 388), and see Yip (1995) for an optimality-theoretic treatment). However, the judgments in these cases are not as clear-cut as one might wish, and our conclusions must remain tentative.

Returning to (118), we find three distinct subtypes of prosodically non-exhaustive reversals (118b–d). Here the medial u/u' factors, even though not empty, still do not contain segmental material. Rather, they cover pure

vocalic moras. In the examples in (123), the factoring of both the base and the argot is prosodically nonexhaustive.

(123) Bilateral prosodic nonexhaustivity ($u=u'=[:]$, (118b))

- a.

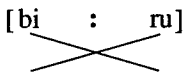
x	u	y	
[bi	:]	ru]	‘beer’
			
[ru	:]	bi]	
y'	u'	x'	

- b.

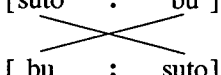
x	u	y	
[suto	:]	bu]	‘stove’
			
[bu	:]	suto]	
y'	u'	x'	

In the other two types, prosodic nonexhaustivity is unilateral, affecting either only the base factoring or only the argot factoring. The first (B-nonexhaustivity, (118c)) amounts to shortening, the second (A-nonexhaustivity, (118d)) to lengthening.

(124) Unilateral prosodic nonexhaustivity

- a. B-Nonexhaustive
($u = [:]$, $u' = \emptyset$, (118c))

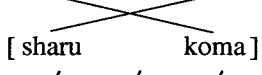
x	u	y	
[koma	:]	sharu]	‘commercial’
			
[sharu		koma]	
y'	u'	x'	

- b. A-Nonexhaustive
($u = \emptyset$, $u' = [:]$, (118d))

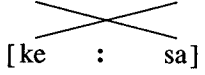
x	u	y	
[sa		ke]	‘sake’
			
[ke	:]	sa]	
y'	u'	x'	

As discussed in section 4 (see (87)), both occur under the regime of the dominant Prosodic Form constraints (Hierarchical Alignment and Nonfinality (F')). The Cross-Anchoring constraint restricts the location of extra-correspondential moras to (B- or A-) medial position (see (92) and (93) in section 4 and the surrounding discussion).

In contrast to the three types of prosodic nonexhaustivity, there is only a single type of segmental nonexhaustivity, namely, the bilateral one ((118e)), illustrated with an example in (125). This is a consequence of high-ranking segmental faithfulness within the group of B,A faithfulness constraints (crucially above MParse; see (88) and (90) in section 4), effectively interdicting any segmental discrepancies between u and u' .

(125) Segmental nonexhaustivity (bilateral) (u, u' are segmental, (118e))

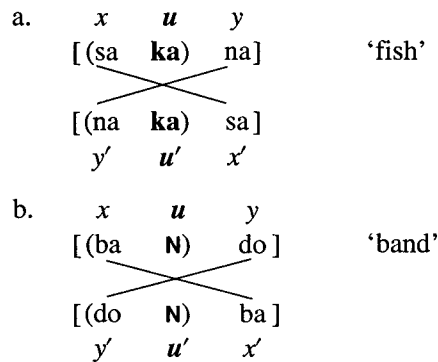

Segmentally nonexhaustive reversals are optimal for FL-bases because of a combination of two factors: On the one hand, exhaustive reversals of the two immediate constituents of PrWd (FL \rightarrow LF) are excluded because of a prosodically disfavored output configuration violating NonFinality; on the other hand, other conceivable ZG-candidates lose against segmentally nonexhaustive reversals because the latter fulfill moraic faithfulness and partially preserve the prosodic role assignment in the base (here, the foottail status of the medial u -element; see (112)–(115) in section 5 for discussion).

Segmentally nonexhaustive reversals are optimal only in this single situation, namely, with trimoraic FL bases. For shorter bases ($< 3\mu$), the absence of segmental nonexhaustivity is unsurprising – there is simply not enough segmental material present for the option to arise in a meaningful way. For 4μ -bases with the structure F+F, exhaustive reversals of the two feet always win over any nonexhaustive reversals because the latter involve additional faithfulness violations (see (102)–(105) in section 5 and the surrounding discussion). The issue becomes more interesting for other types of longer bases. The one variety of 4μ -base not parsable into F+F, namely LHL, is amenable to prosodic nonexhaustive reversal provided H is a syllable with a long vowel (i.e., the medial unreversed u -factor = [:]), as shown in (126).⁵⁷

- (126) a. $\begin{array}{ccc} x & u & y \\ \text{[su(to} & \text{:)} & \text{bu]} \end{array}$ 'stove'
- $\begin{array}{ccc} & \text{[(bu} & \text{:)} & \text{(suto)]} \\ & y' & u' & x' \end{array}$
- b. $\begin{array}{ccc} x & u & y \\ \text{[shi(ro} & \text{:)} & \text{to]} \end{array}$ 'amateur'
- $\begin{array}{ccc} & \text{[(to} & \text{:)} & \text{(shiro)]} \\ & y' & u' & x' \end{array}$

For LHL bases where the dependent mora of the medial H syllable is segmentally filled, however, nonexhaustive reversal would leave a segmental residue, such as the postnuclear nasal *N* and the diphthong element *i* in (127). In contrast to the prosodic nonexhaustivity seen in (126), segmental nonexhaustivity is systematically excluded in such cases.⁵⁸

- (127) a. $\begin{array}{ccc} x & u & y \\ \text{[se(ka} & \text{N)} & \text{do]} \end{array}$ 'second'
- * $\begin{array}{ccc} & \text{[(do} & \text{N)} & \text{(seka)]} \\ & y' & u' & x' \end{array}$
- b. $\begin{array}{ccc} x & u & y \\ \text{[fu(ra} & \text{i)} & \text{to]} \end{array}$ 'flight'
- * $\begin{array}{ccc} & \text{[(to} & \text{i)} & \text{(fura)]} \\ & y' & u' & x' \end{array}$

The same point carries over to $5\mu^+$ -bases, as shown by the examples in (128), none of which has an acceptable argot form (but see note 21 in section 2). Again the impossibility of *segmentally* nonexhaustive reversals contrasts sharply with the fact that *prosodic* nonexhaustivity is a viable option (as evidenced by cases like (124a) above).

- (128) a. HLH:
- $\begin{array}{ccc} x & u & y \\ \text{[(ku} & \text{:)de} & \text{(ta:)]} \end{array}$ 'coup d'état'
- * $\begin{array}{ccc} & \text{[(ta:)} & \text{(de} & \text{ku)]} \\ & y' & u' & x' \end{array}$

b. HHL:

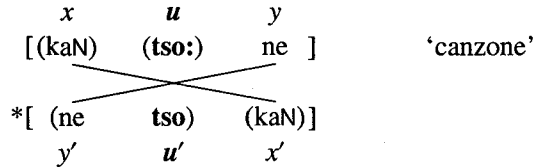

c. LLHL:

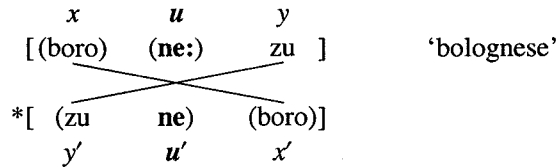

d. HHH:

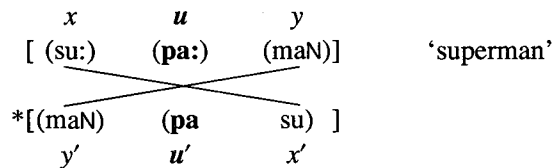

Nonexhaustive reversals with a segmentally-filled *u*-factor are thus the exclusive prerogative of trimoraic FL forms (125). What makes the FL case so special? We speculate that two different faithfulness-related factors are responsible – on the one hand, whether and to what extent the reversal preserves the adjacency relations between the parts of the base, and on the other hand, whether and to what extent prosodic role assignment is invariant between base and argot form.

In terms of the preservation of adjacency relations, the trimoraic base-argot candidate type illustrated in (125) differs substantially from a (hypothetical) quadrimoraic counterpart such as (127a): In ($pa_1-N_2-tsu_3$, $tsu_3-N_2-pa_1$) ((125a)), kana moras adjacent in the base are also adjacent in the argot, and vice versa; in particular, the medial *u*-element [N_2] is invariantly adjacent to [pa_1] and [tsu_3] (with a difference in linear order, which is irrelevant for adjacency per se and falls under the purview of a separate constraint). In contrast, quadrimoraic pairs like ($se_1-ka_2-N_3-do_4$, $do_4-N_3-se_1-ka_2$) ((127a)) show a change in adjacency structure: While the *u*-element [N_3] is adjacent to [do_4] in both base and argot, its other neighbor varies ([ka_2] in the base vs. [se_1] in the argot). Similar discrepancies arise, mutatis mutandis, for the other forms in (128).

We will leave the issue of adjacency with these informal observations since a serious attempt at formalization would raise a host of new issues

beyond the limits of the present paper.⁵⁹ For present purposes, we summarize the conception of adjacency preservation presupposed here in the pair of statements in (129) (where “Adj” stands for the predicate “adjacent,” $x_1, x_2 \subseteq_s I$, $y_1, y_2 \subseteq_s O$, and \mathcal{R}_s denotes the string-extension of some correspondence \mathcal{R}).

(129) a. MaxAdj:

\mathcal{R}_s is adjacency-preserving in direction I-O: Adjacent pairs of substrings in I correspond to adjacent pairs of substrings in O.

$$\forall x_1, x_2, y_1, y_2 [\text{Adj}(x_1, x_2) \wedge x_1 \mathcal{R}_s y_1 \wedge x_2 \mathcal{R}_s y_2] \rightarrow \text{Adj}(y_1, y_2)$$

b. DepAdj:

\mathcal{R}_s is adjacency-preserving in direction O-I: Adjacent pairs of substrings in O correspond to adjacent pairs of substrings in I.

$$\forall x_1, x_2, y_1, y_2 [\text{Adj}(y_1, y_2) \wedge x_1 \mathcal{R}_s y_1 \wedge x_2 \mathcal{R}_s y_2] \rightarrow \text{Adj}(x_1, x_2)$$

Turning to the issue of prosodic role preservation, it is interesting to note that the limitation of segmental nonexhaustivity to FL-bases means that it is in fact limited to a situation where the base and the argot form are exactly identical in terms of their prosodic word structure – both are FL. For all the other types of bases where segmentally nonexhaustive ZG-candidates are serious contenders at all, the PrWd-structures of base and argot differ quite radically, with a shift from some tripartite structure (LFL, FLF, FFL, FFF) to FF.

For trimoraic bases as in (125), the overall FL shape shared by base and argot has a special benefit for the medial u-element: It keeps its exact position within the PrWd, namely, as the tail member of the PrWd-initial foot. The u-elements in larger structures necessarily change their roles. This is a stricter kind of prosodic role faithfulness than the one discussed in the previous section, where the prosodic role was calculated only for position within the foot. One might hypothesize, for the present case, that just as y and x must be cross-anchored, u must be anchored in its PrWd position.

Furthermore, viewed downwards from the perspective of the whole prosodic word, trimoraic nonexhaustive reversals are unique in that ingredients of the initial foot in the base are partially identical to the first foot of the argot form. More concretely, in (130a) the initial B-foot (*teni*) and the initial A-foot (*sumi*) have the second syllable *ni* in common, but in an FF reversal like (130b) the initial B-foot (*kara*) has nothing in common with the initial A-foot (*oke*).

(130)	a.	b.
Base:	(te ni) su	(kara) (oke)
Argot:	(su ni) te	(oke) (kara)

Let us assume that there is some (gradient) constraint focussing on the preservation of the left edge of PrWd, in particular, of the initial foot. This is a kind of faithfulness constraint not concerned with the preservation of the foot-status, foothead-status, etc., of certain substrings and segments but rather with the preservation of the initial foot qua initial-foot-of-PrWd (perhaps: as head, see also Alderete (1995) and McCarthy (1995)). Under this criterion, in (130a) the initial A-foot is partially identical with the initial B-foot, whereas in (130b) there is no similarity (perhaps in the first case the initial feet can count as (imperfect) correspondents of each other but not in the second case). These notions would have to be made more precise to be workable within an optimality-theoretic analysis. But pursuing this line of thought, there is the surprising fact that pitch accent retention effects in argot forms point to the importance of the partial preservation of the initial (head) B-foot in nonexhaustive reversals of FL bases. Accent in Japanese (marked as ['] immediately following the nuclear vowel of the accented syllable) is phonetically manifested by a fall in pitch (see McCawley (1968), Haraguchi (1977), Kubozono (1987), Poser (1984a), Pierrehumbert and Beckman (1988), among others). As pointed out in note 2, the general rule regarding the accentuation of ZG-argot words is straightforward: Under reversal, lexical accentedness yields to unaccentedness, which emerges here and elsewhere as the unmarked accentual state of Japanese words (Akinaga (1985)); see Kubozono (1995) and Katayama (1995) for optimality-theoretic analyses of Japanese accentual patterns). Not surprisingly, unaccentedness is found in the argot when the base itself is unaccented ((131)), but even when the base is lexically accented, the argot output shows no accent, irrespective of the size of the base or the location of the accent within the base (132).⁶⁰

(131)

Base: Unaccented	chi	hai	hima	kusuri	fumeN	yasai	batsugun
Argot: Unaccented	i:chi	i:ha	ma:hi	suriku	menfu	saiya	gunbatsu

'blood', 'ash', 'leisure time', 'drug', 'music score', 'vegetable', 'fantastic'

(132) Deaccentuation

a. Base: Accented 1-2μ Argot: Unaccented FL	hi' i:hi	tsu': u:tsu	pa'N N:pa	hara' ra:ha	na'shi shi:na
b. Base: Accented 3μ Argot: Unaccented FL	mazu'i zuima	shi'miN miNshi	one': ne:o	to:fu' fu:to	chikara' karachi
c. Base: Accented 4μ Argot: Unaccented FF	ko:hi': hi:ko:	ku':ra: ra:ku:	kichiga'i gaikichi	ta'kushi: shi:taku	ike'bana banaike
d. Base: Accented 5-6μ Argot: Unaccented FF	shi'ro:to to:shiro	suto':bu bu:suto	mane'ja: ja:mane		

- a. 'cigarette light (lit.: fire)', 'expert', 'bread', 'stomach', 'doesn't exist';
- b. 'unsavory', 'citizen', 'sister', 'tofu', 'force';
- c. 'coffee', 'air conditioner', 'lunatic', 'taxi', 'flower arrangement';
- d. 'amateur', 'stove', 'manager'

The only cases systematically deviating from this deaccentuation pattern are found precisely among the FL bases that undergo segmentally non-exhaustive reversal. When they have initial accent, such bases retain it in their argot forms (133), irrespective of whether the medial *u* is a full syllable (69a), moraic nasal (69b), diphthongal *i* (69c), vocalic mora (69d), or obstruent mora (69e).⁶¹

(133) Accent Retention

a. Base:	(te'ni)su	(sa'ra)da	(ka'ka)ri	(ki'mu)chi
Argot:	(su'ni)te	(da'ra)sa	(ri'ka)ka	(chi'mu)ki
b. Base:	(pa'N)tsu	(ta'N)go	(ki'N)ka	(ki'N)jo
Argot:	(tsu'N)pa	(go'N)ta	(ka'N)ki	(jo'N)ki
c. Base:	(ta'i)pu	(sa'i)zu	(do'i)tsu	(cho'i)su
Argot:	(pu'i)ta	(zu'i)sa	(tsu'i)do	(su'i)cho
d. Base:	(su':)pu	(ke':)ki	(ka':)bu	(ne':)ya
Argot:	(pu':)su	(ki':)ke	(bu':)ka	(ya':)ne
e. Base:	(ka't)to	(sho'k)ku	(ba't)to	(ryu'k)ku
Argot:	(to'k)ka	(ku's)sho	(to'tsu)ba	(ku'tsu)ryu

- a. 'tennis', 'salad', 'attendant', 'Korean pickle';
- b. 'panties/briefs', 'tango', 'gold piece', 'neighborhood';
- c. 'type', 'size', 'German', 'choice';
- d. 'soup', 'cake', 'curve', 'sister';
- e. '(hair)cut', 'shock', 'bat', 'rucksack'

Unaccented bases of this type yield unaccented argot forms (134), showing that (133) is a case of accent retention and not of accent addition. In other words, a MaxAccent constraint must be exerting its influence.

(134)

Base:	(saka)na	(baN)do	(tai)ko	(be:)su	(tek)ka	(rap)pa
Argot:	(naka)sa	(doN)ba	(koi)ta	(su:)be	(kat)te	(patsu)ra

'fish', 'band', 'drum', 'bass', 'tekka roll', 'trumpet'

Since the general deaccentuation pattern in (132) shows that, once exhaustive reversal takes place, the lexically assigned accentual status is irretrievably lost, it is tempting to attribute the retention of lexical accent in (133) to the fact that only here the initial feet in base and argot form are correspondents of each other (in the sense informally described above), which in turn allows the low-ranking MaxAccent to play a role in the decision. Needless to say, these are speculative remarks that are in need of further exploration.

Returning one last time to the overall typology of reversal types encountered in the ZG-argot and their optimality-theoretic analysis, we conclude the paper with the overview table in (135), which presents the different types together with their classification and their characteristics. Exhaustive reversal occurs when both u and u' are null ((135a)); and non-exhaustive reversal arises when there is a residue, i.e., when either u or u' (or both) are nonnull ((135b–e)). Among nonexhaustive reversals, cases where the remainder is purely prosodic ((135b–d)) (a mora, indicated by the length mark [:]) are distinct from cases where the remainder is a string of segments ((135e)).

(135)

typology of reversals				
exhaustive	nonexhaustive			
	prosodic			segmental
a.	b.	c.	d.	e.
$u=u'=\emptyset$	$u=u'=:$	$u=: u'=\emptyset$	$u=\emptyset u'=:$	$u=u'=\text{seg}$
$x \quad [\quad] \quad y$ $y' \quad [\quad] \quad x'$	$x \quad [:] \quad y$ $y' \quad [:] \quad x'$	$x \quad [:] \quad y$ $y' \quad [\quad] \quad x'$	$x \quad [\quad] \quad y$ $y' \quad [:] \quad x'$	$x \quad [\text{seg}] \quad y$ $y' \quad [\text{seg}] \quad x'$
Base: <i>kara</i> [] <i>oke</i> Argot: <i>oke</i> [] <i>kara</i>	$bi \quad [:] \quad ru$ $ru \quad [:] \quad bi$	$mane \quad [:] \quad ja:$ $ja: \quad [\quad] \quad mane$	$sa \quad [\quad] \quad ke$ $ke \quad [:] \quad sa$	$pa \quad [N] \quad tsu$ $tsu \quad [N] \quad pa$

This paper has shown that recent advances in Optimality Theory (Prince and Smolensky (1993)) make possible a comprehensive and accurate

analysis of what at first glance appears to be a complex reversing argot formation. Pursuing the formal correspondence between ordinary Japanese and the special ZG argot, we find that, just as unmarked properties often emerge in reduplicative structures (Steriade (1988), McCarthy and Prince (1994, 1995)), argot words exhibit the optimal (unmarked) prosodic structures of Japanese. They are otherwise faithful to their bases, both segmentally and prosodically, within limits imposed by the game-specific reversal requirement. The latter is itself defined in correspondence-theoretic terms (as Cross-Anchoring), by a slight extension of anchoring constraints otherwise found in grammar. Apart from its argot-specific formulation, the external constraint-interactive behavior of Cross-Anchoring is identical to that of ordinary optimality-theoretic constraints. Under the combined pressure of Cross-Anchoring and high-ranking prosodic form constraints, argot formation distorts the base in the minimal way. An important result of our study is that the notion of “minimal distortion” operative here turns out to be none else but the principle of minimal violation of a set of ranked constraints, the fundamental tenet of Optimality Theory.

A ZG form is thus not some kind of prosodic or segmental monstrosity but rather a model of style and harmony (albeit with twisted limbs), always as faithful to its origin as it can be and observant of the basic characteristics of the Japanese language. In a more general vein, the two opposing forces that we have seen at play here – minimal distortion (to make some move in the language game at all) and maximal preservation (to make the result comprehensible) – must surely lie at the heart of most such games and argots.

NOTES

* The names of the authors appear in alphabetical order. For helpful comments and suggestions on the topic, we would like to thank John Alderete, Jill Beckman, Mike Hammond, Bruce Hayes, Mark Hewitt, René Kager, Motoko Katayama, Keiko Kojima, Haruo Kubozono, Shigeyuki Koroda, Jason Merchant, Scott Myers, David Perlmutter, Bill Poser, Geoff Pullum, Lisa Selkirk, Junko Shimoyama, Philip Spaelit, Koichi Tateishi, and Suzanne Urbanczyk, as well as three anonymous reviewers. For extensive advice and discussion on an earlier version of this paper, we are grateful to John McCarthy, Jaye Padgett, Alan Prince, Paul Smolensky, and Moira Yip. Our thanks also go to the Japanese community in Rochester, New York, especially to the teachers and parents at the Rochester Japanese School, New York, for their help in the pilot experiment. This work was partially supported by faculty senate grants from the University of California at Santa Cruz and by the National Science Foundation under grant SBR-9510868 to the first and third authors.

¹ One of the authors, YK, has active control of the ZG argot, and the data reported here reflect the version of the game as practiced by this speaker. We have in addition made use of information from other Jazz musicians (in particular, Makoto Takenaka) and from several sources of written material (Yamashita (1975, 1977, 1986), and Yazawa (1980)).

² Our transcription is approximately phonemic and largely follows the Hepburn style of Romanization used by the leading dictionaries with some minor modifications (thus we are using a colon [:] to denote vowel length). Note in particular the following: *chi* = [tʃi], *tsu* = [tsu], *shi* = [ʃi], *ji* = [dʒi], *hi* = [çi], *fu* = [ɸu]; Otherwise, *ky*, etc., denote palatalized consonants [kʲ], etc., and *N* stands for the moraic nasal of Japanese, realized as a nasal glide (assimilating in place to following stop consonants, as in *seNbe*: [sembe:] ‘rice cracker’). Accent marks are systematically omitted in our transcriptions since ZG-forms are uniformly unaccented, whether the input is accented (*ko:hi*: ⇒_{ZG} *hi:ko*: ‘coffee’) or not (*fumeN* ⇒_{ZG} *meNfu* ‘musical score’). There is one systematic group of exceptions to this general deaccentuation in ZG, which will be taken up at the end of the paper in section 6.

³ The reversal typically applies to whole phrases, affecting all lexical words separately. Functional categories remain unchanged and maintain their position (cf. the ending *no* in (1a)). ZG-reversal is often accompanied by grammatical changes that give the ZG-form a nominal character – typical of new word coinage and loanwords in general. Thus the *i*-type (verbal) adjective *mazu-i* (1d) gives rise to the ZG-form *zuima-na*, which is treated as a *na*-type (nominal) adjective, and the verbal continuative form *nomi* (1e) turns into *mi:no*, which is treated as a verbal noun and supported by the light verb *suru*. Since our analysis focuses on the segmental and prosodic properties of the game and is not directly concerned with such attendant grammatical changes, we will in general restrict our illustrations to single lexical items and their ZG reversals, bearing in mind that for competent practitioners of the game (different from the occasional imitator) such examples are usually embedded in a phrasal context, with ZG-reversal applying to all content-word material.

⁴ There are a few lexicalized ZG-forms of bimoraic size: *kane* ‘money’ ⇒ *neka*, *kore* ‘this’ ⇒ *reko*. These are nonproductive and lexicalized (and in addition semantically idiosyncratic: *reko* means ‘steady girlfriend’, and whereas *kane* means both ‘money’ and ‘metal’, *neka* refers only to the former). Other deictic expressions follow the general pattern: *are* ⇒ *re:a* ‘that over there’, *sore* ⇒ *re:so* ‘that (near you)’. There are also some non-ZG-based word reversals that are part of the normal language, such as *yado* ⇒ *doya* ‘hostel’ and *tane* ⇒ *net* ‘seed’. See note 55 in section 5 for other types of (kana) palindromes.

⁵ This kind of markedness effect has since come to be known as the “emergence of the unmarked” (McCarthy and Prince (1994)). We will return to the details in section 3.

⁶ Unfooted syllables are assumed to be immediately dominated by PrWd. Our general notion of the prosodic hierarchy follows the weak layering conception developed and argued for in Itô and Mester (1992) for word-internal prosody (and extended in Selkirk (1993) above the prosodic word).

⁷ Surface-surface relations have also been dubbed ‘output-output’ relations in previous work (McCarthy and Prince (1995), Benua (1995), Orgun (1995)), where ‘input’ = ‘underlying representation’ and ‘output’ = ‘surface representation’. In order to have the terms “input” and “output” available for their general functional usage (a function associates exactly one output value with a given input value, etc.) and to avoid confusion, we will not use them as labels for fixed levels of linguistic representation. For the latter, we use terms such as “lexical structure” and “surface structure”, following the practice of McCarthy (1995).

⁸ The proper place for these phonological markedness considerations, we suggest, is rather at a more fundamental level, namely, in connection with the question of why the kana system employs /ʃ/ [tsu] as a gemination mark, instead of other candidates (see Komatsu (1981) for a presentation of relevant evidence in the context of the historical developments leading to the present-day kana systems).

⁹ For a recent phonological discussion of writing systems, see Poser (1992).

¹⁰ One sometimes encounters the view that language games, word formations, word coinages, etc., that are in any way influenced by orthography are somehow fundamentally tainted and therefore linguistically uninteresting. This has in turn led some analysts to strive for “full phonologization at any cost,” resulting in awkward and problematic phonological generalizations. It seems mistaken to assume that the cognitive mechanisms involved in such cases

are either “purely linguistic” or “purely orthographic.” Surely, any type of knowledge held by the language user can in principle be invoked in such productive word formation, and there is no reason to assume that different kinds of knowledge cannot be simultaneously used. Since orthography is part of the language user’s world knowledge (and is in fact much more closely related to grammatical knowledge than, for example, knowledge of history or carpentry), it would be surprising if it was never tapped into for word games and word coinages, in conjunction with real linguistic knowledge. Cf. in this context also the different but related point made in Anderson (1981, 532–535), who argues that most “spelling pronunciations” in English constitute not some kind of sporadic and loosely language-related activity but linguistic behavior in a central sense, on a par with other instances of the acquisition of lexical knowledge. The ZG argot, and undoubtedly many other similar systems, makes full use of all language-related capacities of a mature speaker.

¹¹ Other kana-based word-formation games in Japanese include the Babibu-language (Haraguchi (1982, 1991)) and the Shiritori game (Katada (1990)).

¹² A position apart is occupied by words consisting of a single vocalic melodeme, as in (i). Such items appear to resist ZG-formation entirely, irrespective of whether the vowel is long or short in the base.

(i) /V/ and /V:/-words

Base:	e	i	o:	e:
Argot:	∅ (??e:e)	∅ (??i:i)	∅ (??o:o)	∅ (??e:e)

‘picture’, ‘stomach’, ‘king’, ‘ray’

The reasons for the lack of acceptable ZG-correspondents in (i) are not immediately apparent. Rounding up the usual suspects, it is tempting to blame the problem on the onset violation in the second syllable of *??e:e*, etc., but the wellformedness of *i:a* (< *ai* ‘love’) in (14) and similar forms thwarts such attempts. On the other hand, diagnosing a putatively fatal OCP-violation becomes implausible in the face of *mi:i* (15) (< *imi* ‘meaning’) (see Myers (1993) and Yip (1995) on the status of the Obligatory Contour Principle in Optimality Theory). More elaborate schemes are certainly thinkable and in general worth pursuing – for example, one could attempt to recruit local conjunction (Smolensky (1995)) in order to disqualify *??e:e*, etc., as “worst-of-the-worst” interactions combining one OCP-violation with two onset violations: *[OCP], **[Onset]. Another line of attack could proceed along functional lines: Conceivably the argot – whose main point is, after all, the reversal of base material – has no proper output for monosegmental bases because there is nothing to reverse. In (i), neither the base *e* nor the base *o:* has two discernible melodic subparts that could be recovered, in reversed order, in *??e:e* and *??o:o*, respectively. This issue will be taken up after our formal analysis of ZG-reversal as Cross-Anchoring is in place (see (122) in section 6).

¹³ With the exception of the nasal segment heard in some dialects, as a free variant of /w/ in word-initial prenasal position, in *uma~Nma* ‘horse’, *ume~Nme* ‘plum’, or *umi~Nmi* ‘ocean’.

¹⁴ Our empirical findings here diverge significantly from those in Taeishi (1989), where even for trimoraic (and shorter) input forms, ZG-reversals of the form F+F are reported: *yanopi:* instead of *yanopi* (< *piyano* ‘piano’), *oini:* instead of *oini* (< *nioi* ‘smell’), with a heavy final syllable; and similarly, *ra:ha:* instead of *ra:ha* (< *hara* ‘stomach’), *i:hi:* instead of *i:hi* (< *hi* ‘cigarette light (lit.: fire)’), etc. The ZG speakers whom we have consulted judge such examples as ill formed and in any case perceive a clear contrast between, for example, *ko:hi:* \Rightarrow_{ZG} *hi:ko:* (**hi:ko*) and *be:su:* \Rightarrow_{ZG} *su:be:* (**su:be:*, with lengthening not triggered by morphological alignment factors, cf. note 18). We have also not found attested examples of the *yanopi:* type in the written sources that we have consulted (it is likely that we are here dealing with a genuine difference in ZG dialects). The systematic existence of trimoraic ZG forms like *yanopi* (not to mention *zu:ja* itself) did not escape Tateishi’s (1989) attention, but within an analysis predicated on a single output template fixed as F+F (an idea taken up in Perlmutter (1992)) such forms remain unexplained. An appeal to some general

quantity fluctuation in ZG (with *su:be* as a variant of *su:be:*, etc.) is problematic because the quantity of the first syllable never vacillates (there is no **hiko:* or **sube:*) and, above all, because of the categorical nature of the contrast mentioned above.

¹⁵ There is one well-known ZG-form that does not obey this generalization, namely *oNna* ‘woman’ \Rightarrow_{ZG} *naoN*. Even though the input has the structure $[_{F}oN] [_{L}na]$, it undergoes immediate constituent reversal and results in $[_{L}na] [_{F}oN]$. The reason for this exceptional behavior might be traced to the fact that the expected moraic reversal of */o N na/* would result in **/na N o/*: in Japanese, the sequence “moraic nasal+vowel” is never found morpheme-internally, nor within a minimal word. A similar example is *unko* ‘feces’ \Rightarrow_{ZG} *ko: uN* in Yamashita (1977, 197) (in this case lengthening produces the FF structure for the argot).

¹⁶ One difference remains, though – the long vowel case does not leave an unreversed segmental remainder like /N/ or /i/ in (21). See section 6 for further discussion.

¹⁷ It is instructive to contrast the straightforward kana account with the difficulties encountered by an attempt to force a “strictly phonological” account of all aspects of the ZG argot. In addition to the task of getting the syllable [tsu] to materialize where needed (see section 1), there is the problem of keeping forms with vowel-length ((22)) distinct from forms with geminate consonants ((24)): The medial mora must in some way be made to retain a memory trace of its erstwhile segmental filling (as vocalic or consonantal). As a formal exercise, it is of course possible to come up with some suitable means of encoding the desired information on the moras in question, but this remains a questionable move to the extent that the concomitant enrichment of the moraic representation is unsupported by strictly linguistic evidence from core areas of phonology, not from language-related activities like games and argots. Another, perhaps more promising, option would be to make full use of the possibilities opened up by Correspondence Theory (McCarthy and Prince (1995)), and formulate some constraint on the segmental filling of correspondent moras by [γ vocalic] elements in Argot and Base. But again, similar questions regarding the descriptive power of two-level constraints arise at the explanatory level (see Orgun (1995) for discussion). Looking beyond the influence of the kana script, (32) and (33) in section 2.3 below present evidence that even the readings of kanji (Chinese characters) become relevant for the ZG-outputs in a particular class of cases.

¹⁸ There is one type of base which, even though extensionally trimoraic, belongs properly with the quadrimoraic cases in terms of its structure. The examples in question are bimorphemic F+L words in which the morpheme boundary coincides with the main prosodic break: {F}+{L}, as in (i) (where “{ }” marks morphemes). The phenomenon is particularly evident in names (which are usually bimorphemic) and compounds:

(i)

B: F+L	{hata}+{no}	{kuro}+{da}	{fuku}+{i}	{gaku}+{sha}	{hana}+{ji}
A: F+F	no: + hata	da: + kuro	i: fu ku	sha: + gaku	ji: + hana

‘Hatano’, ‘Kuroda’, ‘Fukui’, ‘scholar’, ‘nosebleed’ (some of these also have trimoraic ZG-variants with nonexhaustive reversal: *notaha*, etc.)

Building on the analysis of Sino-Japanese compound structure in Itô and Mester (1994), we take it that the second morpheme of these bases, even though consisting only of a light syllable, constitutes a foot by itself (a suggestion first made, on accentual grounds, in Poser (1984a, 97), due to alignment constraints on the mapping between morphological and prosodic structure. When the morphological structure is {L}+{F}, no special lengthening of L takes place in the argot, and the output is the trimoraic F+L: {*te*}+{*gami*} \Rightarrow_{ZG} *gami+te*, **gami+te*: ‘letter’, etc. (see also (110) in section 5).

¹⁹ Even though the kanji influence is evident in the appearance of [chi], this form shows at the same time that the ZG argot is not purely a reverse reading of the kanji characters. A simple reading of the two reversed characters would be *hatsu-ichi* (and not the ZG *patsu-ichi*) because single nongeminated p’s are disallowed in the Sino-Japanese stratum

(see Itô and Mester (1995b)). The appearance of [p] in the argot clearly shows segmental faithfulness to the surface phonology of the base form.

²⁰ Formally, as we will see in section 6, this is another case of nonexhaustive reversal, similar to the one seen in (21) above.

²¹ Some longer argot candidates are judged to be better than others: for 5μ-inputs, we find an array of judgments like *kurisumasu* ⇒_{ZG} *??masurisuku*, *??masukurisu*, **sumasukuri*, ***masukuri*; *taipisuto* ⇒_{ZG} *??sutotaipi*; *kaNtso:ne* ⇒_{ZG} *???neNtso:ka*; *ku:detā* ⇒_{ZG} *??ta:deku:*; and for 6μ-inputs, *su:pa:maN* ⇒_{ZG} *??maNpa:su:*; *jankeNpon* ⇒_{ZG} *??ponkeNjan*. Even though the judgments vacillate (regarding the number of ?'s and *'s), it is clear that there are no fully acceptable outputs (which have neither ? nor *). This is very different from the normal situation, where a single output is consistently judged to be well formed. It is possible that such judgments show evidence for a secondary marked strategy available once the regular ZG strategy fails and no output is possible. Along the lines of the Cross-Anchoring analysis to be developed below in section 4, smaller or larger prosodic units could be selected as anchors, in a way somewhat reminiscent of pied piping in syntax. Further evidence will be needed in order to fruitfully pursue an account of the varying degrees of acceptability.

²² Tateishi (1989) reports the example *purezeNte:shoN* ⇒_{ZG} *zeNpure*, apparently built on a truncated form *purezeN*. However, such examples are sporadic – no general strategy of making overlong inputs amenable to ZG-mapping by means of truncation is available to speakers of the argot.

²³ Tateishi (1989) cites an alternate ZG-form *taNpa*, which is not a possible variant form for YK.

²⁴ We would like to thank Junko Shimoyama for drawing our attention to this difference between diphthongal and monophthongal superheavies.

²⁵ For earlier treatments of similar issues, see Yip (1993) for an analysis of Cantonese loanword adaptations distinguishing two types of faithfulness constraints, and Cabré and Kenstowicz (1995) on truncation in Catalan.

²⁶ For truncation, Benua (1995, 82) notes that correspondence between the lexical input and the truncated word is always mediated by the base form, so that if the base shows epenthesis, deletion, coalescence, or any other lack of faithfulness to the lexical input, such base properties will be automatically carried over to the truncated form. Pete Schult and Philip Spaelti (personal communication) point out that stress-changing English hypocoristics like *P[æ]t* (from *P[ə]lricia*) provide evidence for a direct correspondence between the lexical input and the truncated form since the hypocoristic shows the full vowel and is therefore more faithful to the lexical input than to the base with the reduced vowel. Among other types of truncation in English, we find similar examples: *P[ɔ]li Sci* (from *P[ə]litical Science*), *P[æ]c Bell* (from *P[ə]cific Bell*), etc. In our ZG correspondence model, a similar case might be made for the kanji-influenced patterns (section 2), since the kanji characters arguable carry the lexical phonological information. In this context, a related question arises: Do the base and its associated form (argot, truncatum, etc.) literally have one and the same lexical input? Since the related surface strings are separate words (unlike reduplication) and do have different semantic import, an argument could be made for two independent lexical inputs. Thus, a full model of surface-surface correspondence might have the quadrangular structure in (i) below, with two lexical inputs, rather than the triangular model for reduplication with a single lexical input.

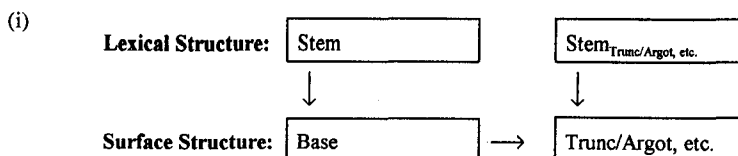

In the present study, however, we will restrict ourselves to the model in (44) abstracting away from this richer network of correspondences.

²⁷ The INDENT (F) constraint family (McCarthy and Prince (1995)), requiring complete featural identity between correspondent segments, does not play a role in our analysis; we are assuming that the computation of segment identity and similarity proceeds in terms of the Feature Class Theory developed in Padgett (1995). Since it allows for a simpler overall analysis, we here make the assumption that moras are phonological constituents that partake in the correspondence relation (see section 4 for discussion), not necessarily mediated through segmental faithfulness (as assumed in McCarthy (1995) and Urbanczyk (1995); in this context, cf. also the problems raised by weight stability phenomena, as in compensatory lengthening (Hayes (1989)), and see Itô and Mester (1992, 11 and 23) on moras as properties of syllables). In general, there are two cross-classificatory groupings of phonological information: (i) lexical vs. derived, and (ii) segmental vs. prosodic. While lexical information is mostly segmental, and prosodic information mostly derived, the other cases exist as well. In particular, the mora prototypically encodes lexical prosodic information.

²⁸ We follow standard OT conventions on tableau format, marking the winner by “**⊕**”, violations as “*”, and fatal violations are signalled by “!”. Shading in tableaux indicate the irrelevance of a constraint to the fate of the candidate.

²⁹ Note that the base form in (48) is already prosodified. This will turn out to be important in section 5.

³⁰ Forms like *shi:me:* are reported for other versions of the argot with a strict FF output template (Tateishi (1989), see note (14)). Such dialect differences can be understood as resulting from slight variations in constraint ranking: The constraint requiring all syllables to be footed is dominated by Dep- μ in the dialect in this paper but dominates Dep- μ in the other dialect. Further differences might relate to the interactions between Cross-Anchoring (section 4) and other constraints.

³¹ For an important precedent, cf. the theoretical consolidation and unification of the model of Lexical Phonology proposed in Kiparsky (1985).

³² If unary branching does not exist (Chomsky (1995), see also note (41)), containment in (53) will always mean proper containment.

³³ John Alderete (electronic communication) suggests that NonFinality plays a similar role in deriving the bipodal prosodic word template characterizing Cupeño habitatives (Crowhurst (1994)).

³⁴ Alternatively, alignment of the left edge of PrWd with F could be required, as suggested by Itô and Mester (1992), building on Itô (1990).

³⁵ Many aspects of the relation between process types and associated faithfulness rankings are replicated in case after case and are unsurprising on functional grounds – e.g., maximal realization of source material is “less important” in reduplication (given the comforting proximity of the base) and in truncation (for brevity’s sake). However, current versions of Optimality Theory do not establish a principled link between the two (it is unclear whether the introduction of (violable?) metaconstraints constitutes an appropriate answer or simply reformulates the problem). We must leave the issue unexplored in the current study, hoping to be able to return to it in future work.

³⁶ This is probably so because a certain opacity threshold is being crossed – a welcome effect for a secret language, but highly detrimental in ordinary language use.

³⁷ I.e., as long as Contiguity is to be respected, in the sense that elements in correspondence must form contiguous substrings in base and reduplicant; see the work cited for further discussion.

³⁸ Is there a more principled way of deriving the correlation between affix position and anchoring? Consider prefixing reduplication as an example. An attempt to explain the Marantzian anchoring correlation could start with the observation that structures observing it have an additional virtue, i.e., besides fulfilling L-Anchoring between base and prefixed reduplicant: They fulfill in addition both L- and R-Anchoring between the base and the

whole prosodic word consisting of reduplicant+base (note that assuming the existence of such a prosodic word category is not always unproblematic, but see McCarthy and Prince (1993a) for a case where the nested PrWd-structures postulated by a well-supported analysis stand in defiance of the overt stress-related prosody of Axinica Campa words). To illustrate, consider the candidate $[_{\text{PrWd}} ka\text{-}karaok\acute{e}]$: Both the beginning (*k*) and the end (*e*) of PrWd are occupied by correspondents of segments located at corresponding edges of the base (taking correspondence to be reflexive). Other candidates, such as *ra-karaok\acute{e}* or *k,e-karaok,e*, violate L-Anchoring between Base and PrWd.

³⁹ This is in some ways reminiscent of “wrong-end” reduplicative anchoring, as in Madurese (Marantz (1982), McCarthy and Prince (1995)).

⁴⁰ The formal development in this section of the paper owes much to a discussion with our colleague Geoff Pullum, who suggested numerous improvements and clarifications.

⁴¹ Chomsky (1995, 246) offers a similar analysis (supplemented with the notion “head”) for syntactic representations in his “bare phrase structure theory.” Note also the abstract similarity with recent proposals in the area of feature structure (see in particular Padgett (1995) on feature classes).

⁴² Since we are dealing with identical correspondents, we will often use this simplified mode of expression, thus “the argot-final substring *da:* is also base-final” is shorthand for “the argot-final substring *da:* corresponds to the base-final substring *da:*,” etc.

⁴³ As an anonymous reviewer points out, what is critical here is that the moraic structure as well as the segmental structure be considered in assessing Cross-Anchoring. In this respect, the argot could be taken to provide a small window into the interface between features and prosodic structure. Some caution is in order, however, because of the influence of the kana orthography (see section 2). An isolated example violating Cross-Anchoring is (*myu:jishan-no rarisa:-ka* (from *sarari:man-ka*) ‘salaryman-ification of musicians’ (Yamashita (1986, 246)), plausibly chosen for reasons of sarcasm (*rari-ru* means ‘to get high on drugs’). For YK, the productively formed argot for *sarari:* is the expected *ri:sara*.

⁴⁴ This constraint also needs to be reconceptualized within the correspondence-theoretic model. We do not pursue the issue here since it is tangential to our main analytical purposes.

⁴⁵ Cf. the entry in the *EDM* (Itô (1987, 1331)): “Let Γ be a correspondence from X to Y , and assume that to any x belonging to the domain A of Γ there corresponds one and only one $y \in Y$, namely, $\Gamma(x) = \{y\}$ for any $x \in A$. Then Γ is called a univalent correspondence.” If, in addition, the inverse correspondence Γ^{-1} is also univalent, then Γ is a one-to-one correspondence. The constraint requiring correspondences to be univalent is named “Integrity” in McCarthy and Prince (1995, 124).

⁴⁶ Note that (94) violates Linearity as well: *h* precedes *i* in the base, but the correspondent of *h* follows a correspondent of *i*.

⁴⁷ A superficial inspection of (96c) might create the impression that this candidate violates Cross-Anchoring (because the initial string *hi* in the argot is identical to the whole base form). However, the relevant condition in (76iii) states that the crossanchoring string in the argot form *hi* be a proper substring of the whole argot form *hi:hi* (and not to the base), a condition obviously fulfilled in (96c).

⁴⁸ The alternate ZG form *taNpa* (reported in Tateishi (1989) but not used by YK) is associated with a different variant of the base, namely *pataN*. Optional prenasal shortening of this kind is encountered elsewhere: *mashi:N ~ mashiN*, *koonbi:fu ~ konbiifu*, *suteiNresu~suteNresu*, *are:Nji~areNji*, etc. (Lovins (1973)).

⁴⁹ For some discussion of open issues relating to minimization and underspecification in underlying representations, see Prince and Smolensky (1993), Inkelas (1994b), Itô, Mester, and Padgett (1995), and Steriade (1995).

⁵⁰ (101a) is weaker than alternative formulations (such as $\forall x \text{ Ft}(x) \rightarrow \exists y [\text{Ft}(y) \wedge xR'y]$) in that it does not itself assert the existence of a correspondent (which would be redundant with respect to Max (46)).

⁵¹ Independent nonprosodic evidence for this setup with distinct BA- and LS correspondence

can be found in the facts of Rendaku, a morphophonemic voicing process affecting initial obstruents of second compound members (Itô and Mester (1986)) in the LS domain: {kuro}+{kane} \Rightarrow_{LS} (kuro)(gane) ‘black metal, iron’, etc. The input for the reversal in the BA domain is always the rendaku-voiced form: (kuro)(gane) \Rightarrow_{BA} (gane)(kuro), etc. A direct L(exical)-A(rgot) correspondence would lead one to expect either *(kane)(kuro) or *(kane)(guro) as the argot form.

⁵² This constraint must be distinguished from the similarly named constraint Head-Dep of Alderete (1995), which requires prosodic heads in the output to have correspondents in the input, militating against stressed or accented epenthetic vowels; see also Kennedy (1994, 60) for a related proposal (“Head Projection”), supported by the stress-avoiding behavior of epenthetic vowels in Dakota.

⁵³ This tableau, and others below, uses MaxFtHd to stand in for the whole family of foot role constraints – the additional violation marks that candidates accrue for the other constraints do not add anything new to the basic picture.

⁵⁴ M-Cat-PCat alignment (or rather: anchoring), in Japanese and elsewhere, constitutes a large field of investigation by itself that we cannot even begin to explore here. For example, the adjectival form /mazul+/i/ in (109), a stem+suffix combination, receives the non-congruent surface footing [ma (zui)] – besides the influence of Onset, this is due to a separate and high-ranking foot alignment constraint characterizing inflectional endings in the verbal and adjectival paradigms of Japanese (discussed in Itô and Mester (1995d)), a constraint whose effects are visible in the accentual behavior of such inflected words.

⁵⁵ IKM (1992, 24–25) note that the trimoraic nonexhaustive reversals ((i)) show a superficial resemblance with palindromes (*kaibun*, lit.: ‘circular letters’) based on kana moras ((ii)):

(i)	te ni su \rightarrow_{BA} su ni te	pa N tsu \rightarrow_{BA} tsu N pa
	テニス スニテ	ハンツ ツンパ°
(ii)	ta ke ya ga ya ke ta	na ga sa ki ya no ya ki za ka na
	タケヤカ* ヤケタ	ナカ* サキヤノ ヤキサ* カナ
	‘The bamboo shop burned down.’	‘The grilled fish of Nagasaki-ya’

Kaibun represent a general word play tradition in Japanese, cf. examples like *rusu-ni kaba-o baka-ni suru* ‘while (you are) gone, (I will) make a fool out of the hippopotamus’ (from Ishizu and Cho (1992), a recent collection of palindromes based on animal themes) or *nikori-to nomi-kiri kimi-no toriko-ni* ‘drinking up with a smile, I’m your captive’ (a well-known beer commercial). Such longer palindromes exist as intellectual amusements (similar to English examples like *Able was I ere I saw Elba*), but once we look beyond three moras, no ZG-form exhibits palindrome properties (e.g., the four-mora (*kara*)(*oke*) cannot be turned into *(*keo*)(*raka*)). In a trimoraic base of the shape (AB)C, the argot form (CB)A, whose decisive advantage is that the medial B preserves its prosodic role, in addition happens to be a palindrome. On the other hand, if a four-mora base (AB)(CD) were turned, palindrome-wise, into (DC)(BA), not a single mora would have preserved its prosodic role. We surmise that no general and productive argot formation strategy can involve such palindromes, probably because not enough material in the argot form can be reliably traced back to the original in order for the correspondence to be established.

⁵⁶ On a limited scale, we conducted experiments with native Japanese, non-ZG speakers. The subjects were asked to perform a “ZG-like” game with 3 μ -words in accordance with their auditory impressions/preferences. The instructions and examples were carefully provided so that the subjects would not be led to assume that they were expected to do the reversal in accordance with a single pattern (i.e., [1]2[3] \rightarrow [3]2[1] or [1][23] \rightarrow [23][1]). Although inconclusive, the results at least tended to point to various factors involved in the judgments of preferred reversal strategies: avoidance of vowel-initial forms, preference for r-medial forms, cohesion of reduplicative forms, analogy to existing ZG forms, etc. When such factors were missing, on the other hand, no preference seemed to arise. For example, *sakana* would be either *nakasa* or *kanasa*, and *kitsune* would be either *netsuki* or *tsuneki*.

⁵⁷ There are two other reasonable argot candidates for *su(to:)bu* besides the winning candidate *(bu:)(suto)*, namely, **(busu)(to:)* and **(to:)(busu)*. One possible route to take in ruling out these candidates is to impose a constituency requirement for *y'* and *x'* in the statement of Cross-Anchoring (see (76) in section 4). That is, the cross-anchors in the argot (but not the base) must be prosodic constituents. The following tableau shows how such a revised Cross-Anchoring constraint works for the three candidate pairs.

(i)

a. ^{MP}	<i>su (to:) bu</i>	<i>(bu :)(suto)</i>	✓ Cross-Anchor (<i>y'</i> and <i>x'</i> are constituents.)
	<i>x y</i>	<i>y' x'</i>	
b.	<i>su (to:) bu</i>	<i>(bu su)(to:)</i>	* Cross-Anchor (<i>x'</i> is not a constituent.)
	<i>x y y'</i>	<i>x'</i>	
c.	<i>su (to:)bu</i>	<i>(to:)(bu su)</i>	* Cross-Anchor (<i>y'</i> is not a constituent.)
	<i>x y</i>	<i>y' x'</i>	

Another possibility is that prosodic faithfulness considerations are involved that go beyond the foot-internal ones (involving foothead and foottail) discussed in section 5. Consider the unfooted PrWd-initial syllable *su* of the base: In (ia), this syllable corresponds to the foot-initial syllable *suto* in the argot. On the other hand, in (ib, c) the same syllable occupies a foot-final position in the argot (*busu*). The idea would be that the syllable that is left-anchored in the B-PrWd should at least be left-anchored in an A-Foot. This could be considered as a kind of anchoring preservation constraint over different prosodic categories: if constituent-initial in B, then constituent-initial in A. Other equally plausible explanations ruling out the two candidates are conceivable, but we find that none of them, including the two options mentioned above, relate immediately to independent and/or interconnecting evidence beyond ZG, and incorporating any one of these constraints into the full analysis therefore seems premature.

⁵⁸ Instead, *(ito)(fura)* is the optimal argot form. A parallel argot form for *se(kan) do* would be **(Ndo)(seka)*, which violates *Nuc/Nas. Different from examples like *N:pa* (see (97) in section 4), this form does not emerge as the winner because it violates a high-ranking constraint on the sonority profile of the foot prohibiting the nonhead member of a foot to surpass the head in sonority (see Prince (1990) for a relevant proposal in this direction). Ranked above MParse, this sonority profile constraint effectively rules out forms like **(Ndo)(seka)*.

⁵⁹ Among other things, there are indications that local constraint conjunction (Smolensky (1995)) might play some role in the calculation of adjacency violations – i.e., the idea that multiple constraint violations, either of different constraints or of the same constraint, are worse when they occur within the same domain (this introduces some kind of “threshold” device into strict-domination OT; see Hewitt and Crowhurst (1995) for a different notion of constraint conjunction). Formally, Smolensky implements the idea within strict lexicographic ordering of constraints by treating the local conjunction of two constraints *C*₁, *C*₂ as a constraint by itself (denoted by “*C*₁&₁*C*₂”), universally ranked above the individual constraints: *C*₁&₁*C*₂ >> {*C*₁, *C*₂}. Double violation of the same constraint (local self-conjunction: *C*&₁*C* = *C*²) is a special case of this, hence *C*² >> *C*. Self-conjunction of adjacency constraints might be responsible for the exclusion of certain segmentally non-exhaustive reversal candidates with bases > 3μ. For example, the double violation of DepAdj in a pair like (i) conceivably counts as worse than an MParse violation (DepAdj² >> MParse >> DepAdj).

(i) (see(128c))

<i>x</i>	<i>u</i>	<i>y</i>		
[(bo,ro ₂)	(ne ₃ :)	zu ₄]	(ro ₂ , ne ₃):	*MaxAdj
*[(zu ₄	ne ₃)	(bo,ro ₂)]	(ne ₃ , bo ₁), (zu ₄ , ne ₃):	**DepAdj → *Dep Adj ²
<i>y'</i>	<i>u'</i>	<i>x'</i>		

⁶⁰ A few exceptions are found among initially accented trimoraic forms, where both base and argot are initially accented: *mo'daŋ* → *da'nmo* 'modern', *ka'mera* → *me'raka* 'camera', *da'buru* → *bu'ruda* 'double'. The first of these is a well-established and arguably lexicalized form; the second and third are interesting in that nonexhaustive reversal would result in the dispreferred *r*-initial forms *ra'meka* and *ru'buda*. In light of the remarks below, one could view the outcome in these cases as resulting from the composition of two permutations (123 → 321 → 231, with the intermediate stage crucial for accent retention), posing an interesting puzzle for the nonderivational framework of current Optimality Theory.

⁶¹ We know of two forms that are exceptions to this subgeneralization regarding non-exhaustive trimoraic reversals. They exhibit the usual deaccentuation pattern: *bi':ru* → *ru:bi* 'beer', *ko':ra* → *ra:ko* 'Coca Cola'.

REFERENCES

- Akinaga, Kazuo (1985) "Kyootuugo no akusento (Accent of Standard Japanese)," *NHK Pronunciation and Accent Dictionary*, NHK, Tokyo, 70–116.
- Alderete, John (1995) "Faithfulness to Prosodic Heads," Ms., University of Massachusetts, Amherst.
- Anderson, Stephen R. (1981) "Why Phonology isn't "Natural", "*Linguistic Inquiry* 12.4, 493–539.
- Archangeli, Diana (1991) "Syllabification and Prosodic Templates in Yawelmani," *Natural Language and Linguistic Theory* 9, 231–283.
- Bagemihl, Bruce (1989) "The Crossing Constraint and 'Backwards Languages'," *Natural Language and Linguistic Theory* 7, 481–550.
- Benua, Laura (1995) "Identity Effects in Morphological Truncation," in J. Beckman, L. Walsh Dickey and S. Urbanczyk (eds.), *Massachusetts Occasional Papers in Linguistics [UMOP] 18: Papers in Optimality Theory*, GLSA, Amherst, MA. pp. 77–136.
- Cabr , Teresa and Michael Kenstowicz (1995) "Prosodic Trapping in Catalan," *Linguistic Inquiry* 26, 694–704.
- Carney, Edward (1994) *A Survey of English Spelling*, Routledge, London and New York.
- Chomsky, Noam (1995) *The Minimalist Program*, MIT Press, Cambridge.
- Chomsky, Noam and Morris Halle (1968) *The Sound Pattern of English*, Harper and Row, New York.
- Crowhurst, Megan J. (1994) "Foot Extrametricality and Template Mapping in Cupe o," *Natural Language and Linguistic Theory* 12, 177–202.
- Hammond, Michael (1995) "There is No Lexicon!," Ms., University of Arizona, Tucson.
- Haraguchi, Shosuke (1977) *The Tone Pattern of Japanese: An Autosegmental Theory of Tonology*, Kaitakusha, Tokyo.
- Haraguchi, Shosuke (1982) "An Autosegmental Theory: Its Expansion and Extension," *Journal of Linguistic Research* 2, 59–80.
- Haraguchi, Shosuke (1991) *A Theory of Stress and Accent*, Foris, Dordrecht.
- Hayes, Bruce (1989) "Compensatory Lengthening in Moraic Phonology," *Linguistic Inquiry* 20, 253–307.
- Hayes, Bruce (1995) *Metrical Stress Theory: Principles and Case Studies*, The University of Chicago Press, Chicago.
- Hewitt, Mark and Megan Crowhurst (1995) "Conjunctive Constraints and Templates in Optimality Theory," Ms., University of British Columbia and University of North Carolina.
- Hock, Hans Henrich (1986) *Principles of Historical Linguistics*, Mouton de Gruyter, Amsterdam.
- Hyman, Larry (1985) *A Theory of Phonological Weight*, Foris, Dordrecht.
- Inkelas, Sharon (1989) *Prosodic Constituency in the Lexicon*, Ph.D. Dissertation, Stanford

- University. [Published 1991, Outstanding Dissertations in Linguistics series, Garland, New York].
- Inkelas, Sharon (1994a) "Exceptional Stress-attracting Suffixes in Turkish: Representation vs. the Grammar," in R. Kager, H. v.d. Hulst and W. Zonneveld (eds.), *Proceedings of the Utrecht Workshop on Prosodic Morphology*, Mouton, The Hague.
- Inkelas, Sharon (1994b) "The Consequences of Optimization for Underspecification," Ms., University of California, Berkeley.
- Ishizu, Chihiro and Shinta Chō (1992) *Masaka-sakasama – Dōbutsu Kaibunshū* [Upside down indeed! – Animal palindrome collection], Kawade Shobō, Tokyo.
- Itō, Junko (1986) *Syllable Theory in Prosodic Phonology*, Ph.D. Dissertation, University of Massachusetts, Amherst. [Published 1988, Outstanding Dissertations in Linguistics series, Garland, New York.]
- Itō, Junko (1989) "A Prosodic Theory of Epenthesis," *Natural Language and Linguistic Theory* 7, 217–259.
- Itō, Junko (1990) "Prosodic Minimality in Japanese," in K. Deaton, M. Noske and M. Ziolkowski (eds.), *CLS 26-II: Papers from the Parasession on the Syllable in Phonetics and Phonology*, pp. 213–239.
- Itō, Junko and Armin Mester (1986) "The Phonology of Voicing in Japanese: Theoretical Consequences for Morphological Accessibility," *Linguistic Inquiry* 17, 49–73.
- Itō, Junko and Armin Mester (1991) *The Prosodic Phonology of Japanese*, Class Reader LINS 224, LSA Summer Linguistic Institute, University of California at Santa Cruz.
- Itō, Junko and Armin Mester (1992) "Weak Layering and Word Binariness," *Linguistics Research Center Report No. 92-09*, University of California at Santa Cruz, Revised version to appear in *Linguistic Inquiry*.
- Itō, Junko and Armin Mester (1994) "Stem and Word in Sino-Japanese," to appear in T. Otake and A. Culter (eds.), *Phonological Structure and Language Processing: Cross-Linguistic Studies*, [Speech Research Series. 12.] Mouton de Gruyter, Berlin.
- Itō, Junko and Armin Mester (1995a) "Japanese Phonology," in J. Goldsmith (ed.), *Handbook of Phonological Theory*, Blackwell, Cambridge, Massachusetts, 817–838.
- Itō, Junko and Armin Mester (1995b) "The Core-Periphery Structure of the Lexicon and Constraints on Reranking," in J. Beckman, L. Walsh Dickey and S. Urbanczyk (eds.), *University of Massachusetts Occasional Papers in Linguistics [UMOP] 18: Papers on Optimality Theory*, GLSA, Amherst, MA., pp. 181–210.
- Itō, Junko and Armin Mester (1995c) "Hierarchical Alignment and Binariness," Talk presented at TREND (UC Santa Cruz, April 1995) and GLOW (University of Tromsø, Norway, May 1995).
- Itō, Junko and Armin Mester (1995d) "Accent Alignment," Talk presented at GLOW (University of Tromsø, Norway, May 1995).
- Itō, Junko, Yoshihisa Kitagawa, and Armin Mester (1992) "Prosodic Type Preservation in Japanese: Evidence from *zūjū-go*," *Linguistics Research Center Report No. 92-08*, University of California at Santa Cruz.
- Itō, Junko, Armin Mester, and Jaye Padgett (1995) "Licensing and Underspecification in Optimality Theory," *Linguistic Inquiry* 26, 571–613.
- Itō, Kiyosi, ed. (1987) *Encyclopedic Dictionary of Mathematics [EDM]*, MIT Press, Cambridge.
- Kager, René (1993) "Alternatives to the Iambic-Trochaic Law," *Natural Language and Linguistic Theory* 11, 381–432.
- Katada, Fusa (1990) "On the Representation of Moras: Evidence from a Language Game," *Linguistic Inquiry* 21, 641–645.
- Katayama, Motoko (1995) "Loanword Accent and Minimal Reranking in Japanese," in Walker, R., O. Lorentz, and H. Kubozono (eds.), *Phonology at Santa Cruz (PASC) 4*, Linguistics Research Center, UC Santa Cruz, pp. 1–12.
- Kennedy, Chris (1994) "Morphological Alignment and Head Projection," in J. Merchant

- and R. Walker (eds.), *Phonology at Santz Cruz (PASC) 3*, Linguistic Research Center, UC Santa Cruz, pp. 47–65.
- Kiparsky, Paul (1985) “Some Consequences of Lexical Phonology,” *Phonology Yearbook* 2, 82–138.
- Kitagawa, Yoshihisa (1984) “Notes on zuuja-go,” Ms., University of Massachusetts at Amherst.
- Komatsu, Hideo (1981) *Nihongo on On’in [Japanese Phonology]*, Chūokōronsha, Tokyo.
- Kubozono, Haruo (1987) *The Organization of Japanese Prosody*, Ph.D. Dissertation, University of Edinburgh.
- Kubozono, Haruo (1991) “Nihongo no onsetu kyōkai to onseturyō [Syllable boundary and syllable weight in Japanese],” *Japanese Phonetics Society Bulletin*, 17–22.
- Kubozono, Haruo (1995) “Constraint Interaction in Japanese Phonology: Evidence from Compound Accent,” in Walker, R., O. Lorentz, and H. Kubozono (eds.), *Phonology at Santa Cruz [PASC] 4*, Linguistics Research Center, UC Santa Cruz, pp. 21–38.
- Lovins, Julie B. (1973) *Loanwords and the Phonological Structure*, Ph.D. Dissertation, University of Chicago. [Distributed by the Indiana University Linguistics Club 1995].
- Marantz, Alex (1982) “Re-Reduplication,” *Linguistic Inquiry* 13, 435–482.
- McCarthy, John J. (1995). “Extensions of Faithfulness: Rotuman Revisited,” Ms., University of Massachusetts, Amherst.
- McCarthy, John J. and Alan S. Prince (1986) *Prosodic Morphology*, Ms., University of Massachusetts at Amherst and Brandeis University.
- McCarthy, John J. and Alan S. Prince (1990) “Foot and Word in Prosodic Morphology: The Arabic Broken Plural,” *Natural Language and Linguistic Theory* 8, 209–283.
- McCarthy, John J. and Alan S. Prince (1993a) *Prosodic Morphology I: Constraint Interaction and Satisfaction*, Ms., University of Massachusetts, Amherst, and Rutgers University. [To appear, MIT Press, Cambridge].
- McCarthy, John J. and Alan S. Prince (1993b) “Generalized Alignment,” in G. Booij and J. van Marle (eds.), *Yearbook of Morphology*, pp. 79–153.
- McCarthy, John J. and Alan S. Prince (1994) “The Emergence of the Unmarked: Optimality in Prosodic Morphology,” in M. Ganzález (ed.), *Proceedings of NELS 24*, GLSA, Amherst, MA, pp. 333–379.
- McCarthy, John J. and Alan S. Prince (1995) “Faithfulness and Reduplicative Identity,” in J. Beckman, L. Walsh Dickey, and S. Urbanczyk (eds.), *University of Massachusetts Occasional Paper in Linguistics [UMOP] 18: Papers in Optimality Theory*, GLSA, Amherst, MA, pp. 249–384.
- McCawley, James D. (1968) *The Phonological Component of a Grammar of Japanese*, Mouton, The Hague.
- Mester, Armin (1990) “Patterns of Truncation,” *Linguistic Inquiry* 21, 478–485.
- Mester, Armin (1994) “The Quantitative Trochee in Latin,” *Natural Language and Linguistic Theory* 12, 1–61.
- Myers, Scott (1993) “OCP Effects in Optimality Theory,” Ms., The University of Texas at Austin.
- Nespor, Marina and Irene Vogel (1986) *Prosodic Phonology*, Foris, Dordrecht.
- Orgun, Cemil Orhan (1995) “Correspondence and Identity Constraints in Two-level Optimality Theory,” Paper presented at WCCFL.
- Padgett, Jaye (1995) “Feature Classes,” in J. Beckman, L. Walsh Dickey, and S. Urbanczyk (eds.), *University of Massachusetts Occasional Papers in Linguistics [UMOP] 18: Papers in Optimality Theory*, GLSA, Amherst, MA, pp. 385–420.
- Partee, Barbara H. (1978) *Fundamentals of Mathematics for Linguistics*, Greylock Publishers, Stamford, Conn.
- Perlmutter, David (1992) “Pervasive Word Formation Patterns in a Grammar,” Paper presented at Berkeley Linguistic Society.

- Pierrehumbert, Janet, and Mary Beckman (1988) *Japanese Tone Structure*, MIT Press, Cambridge.
- Poser, William (1984a) *The Phonetics and Phonology of Tone and Intonation in Japanese*, Ph.D. Dissertation, MIT.
- Poser, William (1984b) "Hypocoristic Formation in Japanese," in M. Wescoat et al. (eds.), *WCCFL 3*, pp. 218–229.
- Poser, William J. (1990) "Evidence for Foot Structure in Japanese," *Language* 66, 78–105.
- Poser, William J. (1992) "The Structural Typology of Phonological Writing," Talk delivered at the Linguistic Society of America.
- Prince, Alan S. (1990) "Quantitative Consequences of Rhythmic Organization," in K. Deaton, M. Noske, and M. Ziolkowski (eds.), *CLS 26-II: Papers from the Parasession on the Syllable in Phonetics and Phonology*, pp. 335–398.
- Prince, Alan S. and Paul Smolensky (1993) *Optimality Theory Constraint Interaction in Generative Grammar*, Ms., Rutgers University and University of Colorado, Boulder. [To appear, MIT Press.]
- Pyle, Charles (1972) "On Eliminating BMs," *Proceedings of CLS 8*, 516–532.
- Rotenberg, Joel (1978) *The Syntax of Phonology*, Ph.D. Dissertation, MIT.
- Selkirk, Elisabeth O. (1984) *Phonology and Syntax: The Relation between Sound and Structure*, MIT Press, Cambridge.
- Selkirk, Elisabeth O. (1993) "The Prosodic Structure of Function Words," Ms., University of Massachusetts, Amherst. [To appear in K. Demuth and J. Morgan (eds.), *Signal to Syntax*, Laurence Erlbaum Assoc.]
- Smolensky Paul (1995) "On the Internal Structure of the Constraint Component Con of UG," Talk presented at University of Arizona, March 1995.
- Spaelti, Philip (1994) "Weak Edges and Final Geminates in Swiss German," in M. Gonzalez (ed.), *Proceedings of NELS 24*, GLSA, University of Massachusetts, Amherst, pp. 573–588.
- Steriade, Donca (1988) "Reduplication and Syllable Transfer in Sanskrit and Elsewhere," *Phonology* 5, 73–155.
- Steriade, Donca (1995) "Underspecification and Markedness," in J. Goldsmith (ed.), *Handbook of Phonological Theory*, Blackwell, Cambridge, Massachusetts, pp. 114–174.
- Suzuki, Hisami (1995) "Minimal Words in Japanese," *Proceedings of CLS 31*.
- Urbanczyk, Suzanne (1995) "Double Reduplication in Parallel," in J. Beckman, L. Walsh Dickey, and S. Urbanczyk (eds.), *University of Massachusetts Occasional Papers in Linguistics [UMOP] 18: Papers in Optimality Theory*, GLSA, Amherst, MA, pp. 499–532.
- Tateishi, Koichi (1989) "Theoretical Implications of the Japanese Musician's Language," *WCCFL 8*, 384–398.
- Yamashita, Yōsuke (1975) *Fūun Jazu Chō* [Turbulent Jazz Notes], Ongaku-no-Tomo-Sha, Tokyo.
- Yamashita, Yōsuke (1977) *Piano-hiki Yojire-Tabi* [A Piano-player's Twisted Journey], Tokuma-Shoten, Tokyo.
- Yamashita, Yōsuke (1986) *Amerika-Rannyū Kotohajime* [Commencing the Raid on America], Bunshun Bunko, Tokyo.
- Yazawa, Eikichi (1980) *Yazawa-Eikichi-Gekiron-Shū – Nariagari* [A Parvenu – Heated Discussions by Eikichi Yazawa], Kadokawa-Bunko, Tokyo.
- Yip, Moira (1993) "Cantonese Loanword Phonology and Optimality Theory," *Journal of East Asian Linguistics* 2, 261–291.
- Yip, Moira (1995) "Identity Avoidance in Phonology and Morphology," Ms., UC Irvine, *Proceedings of the Conference on Morphology and its Relation to Syntax and Phonology*, UC Davis.

Received 5 August 1992

Revised 2 February 1996

Junko Itô
Board of Studies in Linguistics
Stevenson College
University of California
Santa Cruz, CA 95064
ito@ling.ucsc.edu

Yoshihisa Kitagawa
Dept. of Linguistics
Indiana University
Memorial Hall 322
Bloomington, IN 40475
kitagawa@ucs.indiana.edu

Armin Mester
Board of Studies in Linguistics
Stevenson College
University of California
Santa Cruz, CA 95064
mester@ling.ucsc.edu